

## Dual Agent HANDLINE NOZZLES

FDD010

- Rugged Aluminum Construction
- Capable of Simultaneous Foam/Dry Chemical Operation
- 60 GPM Foam/Water Straight Stream or Fan Pattern
- Aspirated Versions Available
- Non-Aspirated Versions Available



### Description

The Feecon Model DANA Nozzle (Dual Agent Non-Aspirating) is a lightweight, compact, versatile fire fighting tool. The nozzle is designed to discharge dry chemical agent at rates up to eight pounds per second (3.6 Kg/s) and AFFF foam solution at rates up to 100 GPM (379 LPM).

The AFFF foam solution is produced by air entrainment and mixing within the

discharge stream rather than within a foam tube. The nozzle discharge pattern is variable between a straight stream and a solid conical fog. The range of the 60 GPM (227 LPM) nozzle is 75 feet (23 meters) at 100 PSI (7 Bar).

The dry chemical agent is delivered in an effective stream reaching 70 feet (21 meters) at 100 PSI (7 Bar) when discharging five pounds per second (2.3 Kg/s).

The model DANA Nozzle is constructed of anodized aluminum and weighs 4 pounds 14 ounces (2.2 Kg). It features trunion mounted ball valves, for shut-off, that operate easily at all normal discharge pressures. Side by side valve handles allow AFFF and dry chemical agent discharge sequentially or simultaneously. The AFFF nozzle exterior is constructed of molded rubber for added protection.

### Model DANA Non-Aspirating

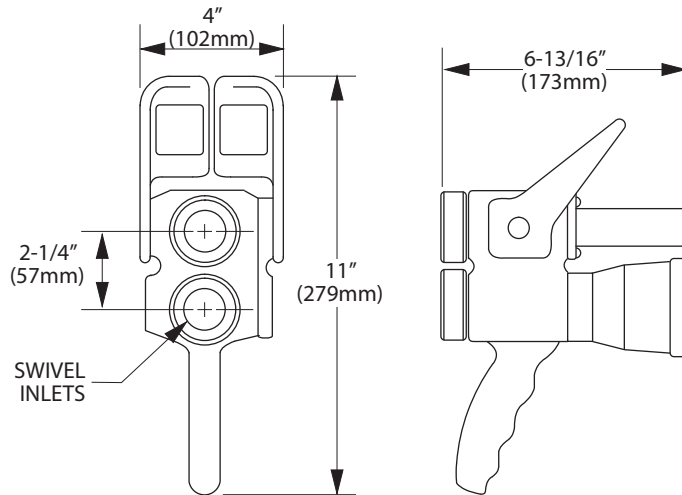

### ORDERING INFORMATION

Feecon Model DANA Nozzle

Part Number	Flow at 100 PSI (7 Bar)		Swivel Connection - Inch (mm)	
	Dry Chemical	AFFF/Water	Dry Chemical	AFFF/Water
3220-6041-0	5 PPS (2.3 Kg/S)	60 GPM (227 LPM)	1" NH (25)	1" NH (25)
3220-6042-0	5 PPS (2.3 Kg/S)	60 GPM (227 LPM)	1" NPSH (25)	1" NPSH (25)
3220-6038-7	5 PPS (2.3 Kg/S)	60 GPM (227 LPM)	1" BSP (25)	1" BSP (25)
3220-6008-0	8 PPS (3.6 Kg/S)	95 GPM (360 LPM)	1" NH (25)	1-1/2" NH (38)

## Dual Agent HANDLINE NOZZLES

FDD010

### Description

The Feecon Model DA Nozzle (Dual Agent Aspirating) is a lightweight, compact, versatile fire fighting tool. The nozzle is designed to discharge dry chemical agent at rates up to eight pounds per second (3.6 Kg/s) and AFFF foam solution at rates up to 100 GPM (379 LPM).

The AFFF foam solution is produced by air aspiration and mixing within the

foam tube. Air aspirated AFFF foam solution retains its film forming capability longer than nonaspirated AFFF. The nozzle discharge pattern is variable between a straight stream and a flat fan dispersed pattern. The range of the 60 GPM (227 LPM) nozzle is 65 feet (20 meters) at 100 PSI (7 Bar).

The dry chemical agent is delivered in an effective stream reaching 70 feet (21 meters) at 100 PSI (7 Bar) when dis-

charging five pounds per second (2.3 Kg/s).

The model DA Nozzle is constructed of anodized aluminum and weighs 7 pounds 2 ounces (3.2 Kg). It features trunion mounted ball valves, for shut-off, that operate easily at all normal discharge pressures. Side by side valve handles allow AFFF and dry chemical agent discharge sequentially or simultaneously.

### Model DA Aspirating

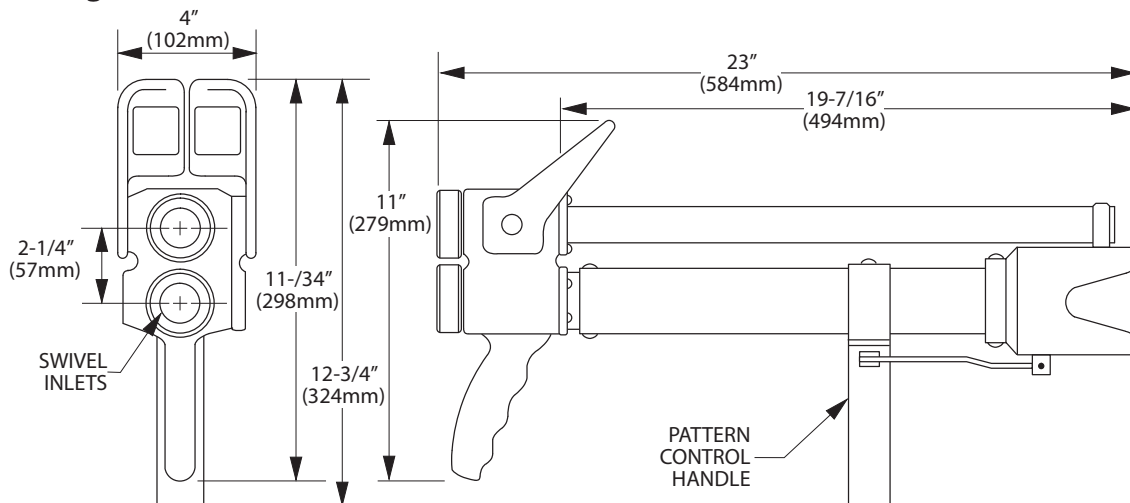

### ORDERING INFORMATION

Feecon Model DA Nozzle

Part Number	Flow at 100 PSI (7 Bar)		Swivel Connection - Inch (mm)	
	Dry Chemical	AFFF/Water	Dry Chemical	AFFF/Water
3220-6036-0	5 PPS (2.3 Kg/S)	60 GPM (227 LPM)	3/4" NPSH (19)	1" NPSH (25)
3220-6036-5	5 PPS (2.3 Kg/S)	60 GPM (227 LPM)	1" NH (25)	1" NH
3220-6007-0	8 PPS (3.6 Kg/S)	95 GPM (360 LPM)	1" NH (25)	1-1/2" NH (38)

### National Foam

350 East Union Street, West Chester, PA 19382, USA  
24hr RED ALERT® : 610-363-1400 • Fax: 610-524-9073

[www.nationalfoam.com](http://www.nationalfoam.com)

National Foam operates a continuous program of product development. The right is therefore reserved to modify any specification without prior notice and National Foam should be contacted to ensure that the current issues of all technical data sheets are used.

© National Foam