

NIHILATOR

JUMBO TANK PROTECTION SYSTEM

NDD105

- Effective Fixed Jumbo Tank Device
- Kills Exposed Burning Fuel In Center Donut of Jumbo Tanks
- Suitable For Fixed or Semifixed Systems
- Compatible With All Foams
- Custom Flows Available
- Dual Aspiration Foam Maker

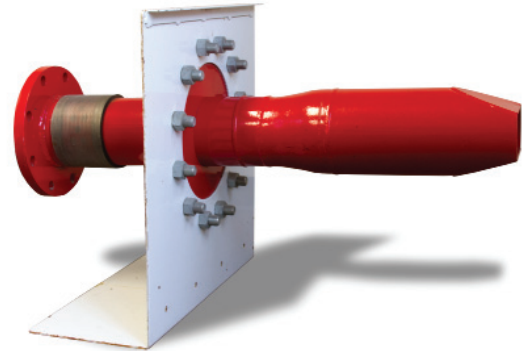

Description

The Nihilator Tank Mounted Foam Nozzle is a revolutionary new concept designed to help meet the daunting challenge of protecting jumbo-sized flammable liquid storage tanks. Installed just below the top rim of the tank, the Nihilator is designed to discharge expanded foam directly onto the surface of a flammable or combustible liquid for fire extinguishment or vapor suppression. The Nihilator produces a fully aspirated foam blanket for maximum foam expansion and 25% drainage life.

The Nihilator is designed to deliver the foam stream approximately 53 feet (16 m) out from the tank wall. The foam will land on the fuel surface and slide to the center of the tank, overcoming the problem of getting foam to flow across the vast surface of jumbo storage tanks. On floating roof tanks, the Nihilator is used in conjunction with rim seal protection to insure complete coverage.

The Nihilator is compatible with all types of foam concentrate: protein, fluoroprotein, AFFF, and AR-AFFF

proportioned at any of the standard percentages of 1, 3, or 6%. Installed on the sidewall of vertical storage tanks above the maximum product level, piping coupled to the unit can be linked to a fixed foam proportioning system, or terminated a safe distance from the tank where foam solution can be delivered from foam fire apparatus or portable foam proportioning equipment. In either case, the Nihilator alleviates the need for firefighters to approach a dangerous situation to set up manual appliances. The mounting configuration of approximately 3° above horizontal reduces plunging of the foam that causes fuel pickup and diminished foam performance. Incidents involving jumbo-sized storage tanks leave little margin of safety. For this reason, it is critical that all of the foam is discharged onto the product for the most effective utilization of foam resources. With the Nihilator, foam is delivered directly into the tank alleviating concerns of foam from ground-based monitors not reaching the tank through nozzle fallout, thermal column updrafts, and wind shifts.

Features

- Discharge foam directly onto fuel surface for best utilization of foam resources
- Overcome difficulties penetrating thermal updrafts
- Eliminate nozzle fallout from ground-based monitors
- Fully aspirated for superior foam quality
- Compatible with all types of foam concentrates
- High performance corrosion resistant polyester finish
- Integral double air induction foam maker

Capacity

The Nihilator is designed to flow 1000 gpm @ 70 psi (3785 lpm @ 4.8 bar) with a range of 53 feet (16 m), at 3° nozzle elevation, in still air. Additional range is gained by sliding across fuel surface due to low trajectory angle.

ORDERING INFORMATION

Part Number	Description	Weight
1254-2035-0	Nihilator Tank Nozzle 1000 GPM @ 70 PSI (Red)	105 lbs. (48 kg.)
1254-2036-0	Nihilator Tank Nozzle 1000 GPM @ 70 PSI (Yellow)	105 lbs. (48 kg.)

NIHILATOR JUMBO TANK PROTECTION SYSTEM

NDD105

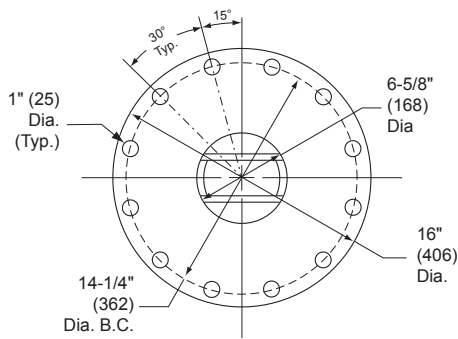
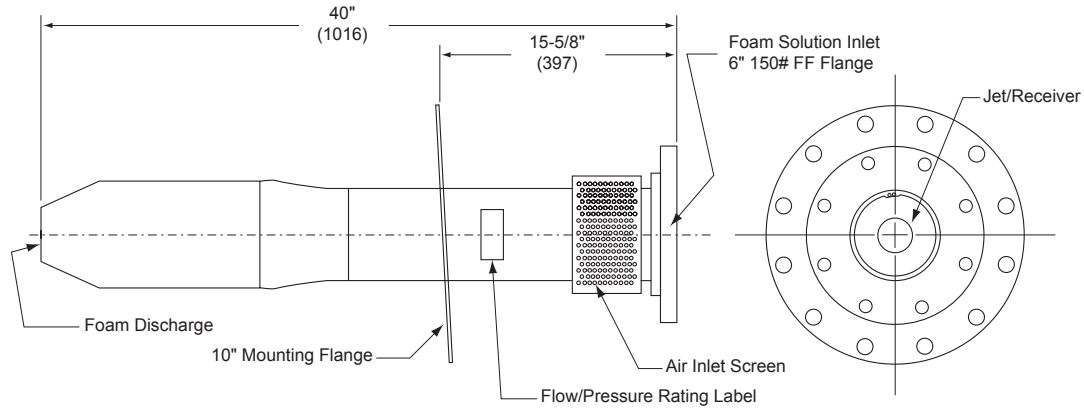

10" Mounting Flange

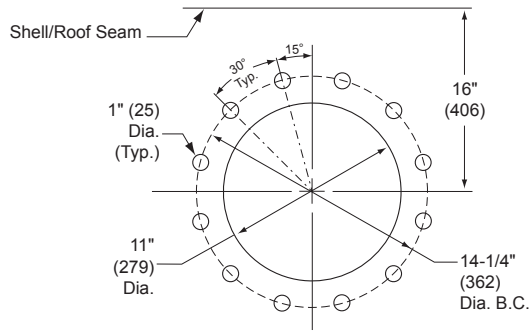

**SHELL PENETRATION DETAIL
- FULL SURFACE SYSTEM -**

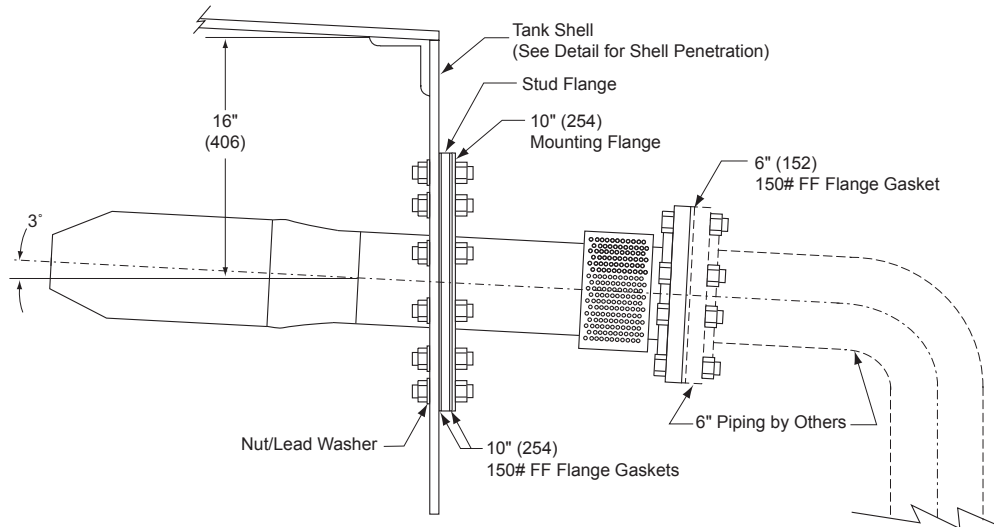

**INSTALLATION DETAIL
- PROJECTING FOAM MAKER -**

NIHILATOR JUMBO TANK PROTECTION SYSTEM

NDD105

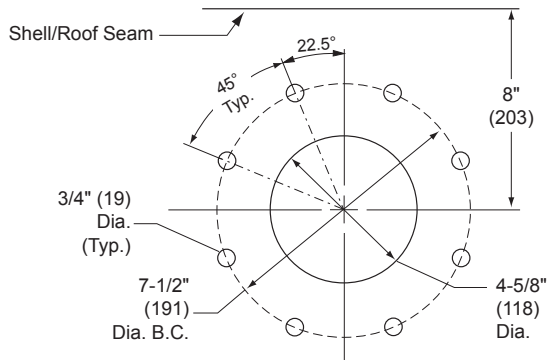

SHELL PENETRATION DETAIL
- RIM SEAL SYSTEM -
SPS-9 FOAM MAKER

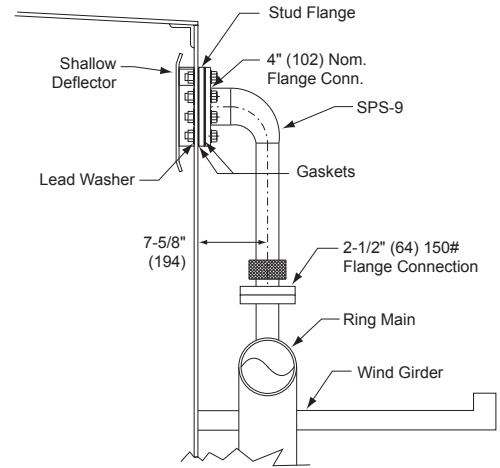

INSTALLATION DETAIL
- RIM SEAL SYSTEM FOAM APPLICATOR MOUNTING -

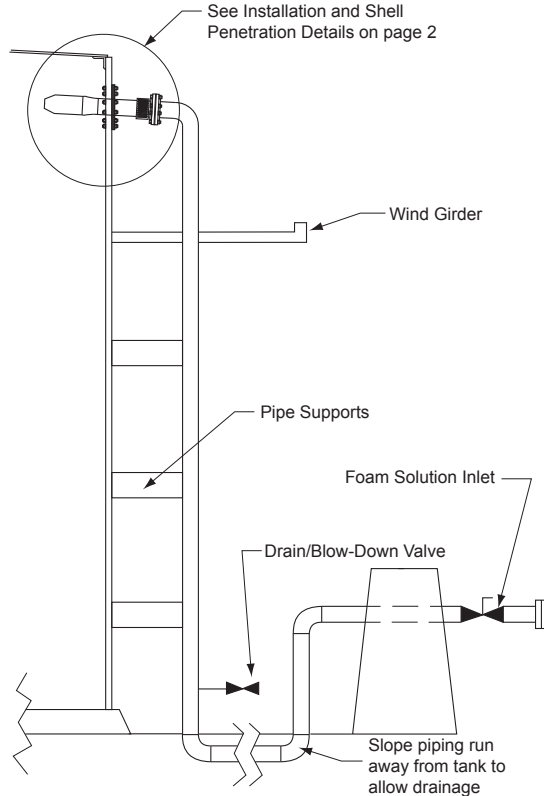

FULL SURFACE PROTECTION SYSTEM
VIEW A-A (FROM PAGE 4)

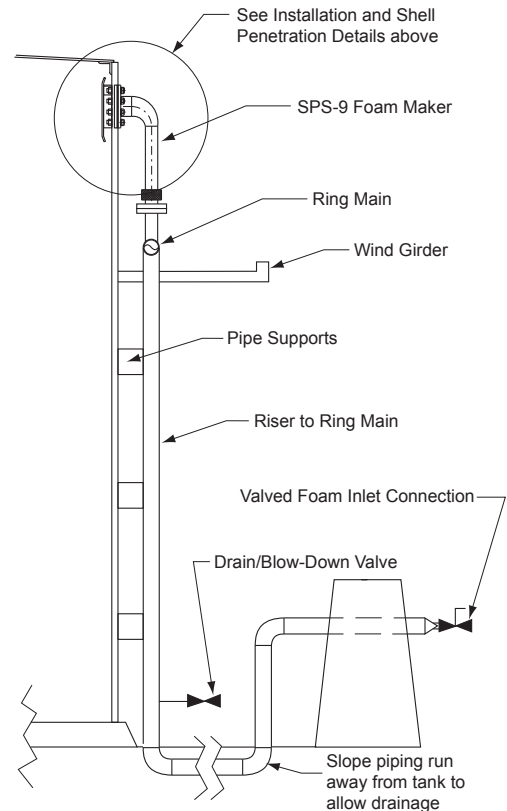

RIM-FIRE PROTECTION SYSTEM
VIEW B-B (FROM PAGE 4)

NIHILATOR JUMBO TANK PROTECTION SYSTEM

NDD105

