

FOAM TOTE PLATFORM

NME060

Value Minded Foam Application System

- High Capacity Skid Mounted Foam System
- Easily Relocated And Transported
- Self-inducting Nozzle, No Foam Pump Needed
- Tote Easily Removed And Replaced
- Municipal/Industrial Applications

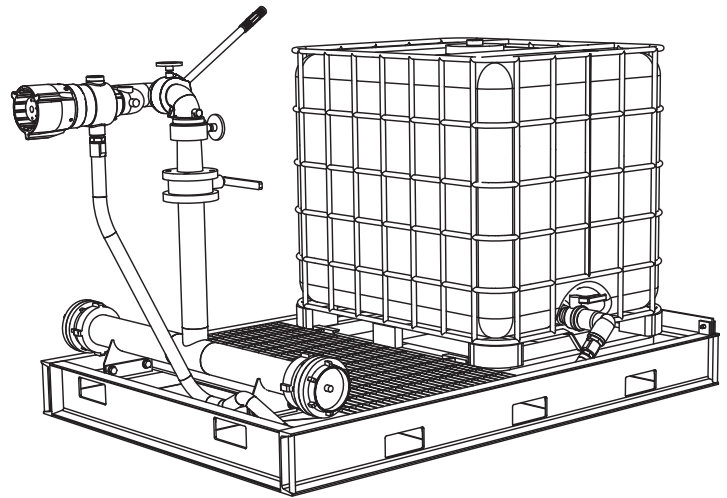

Description

The Foam Tote Platform is a simple means for providing an easily transported high capacity fire fighting system. The Foam Tote Platform consists of a structural steel base outfitted with a water supply manifold, water flow control valve, monitor, and Gladiator Self-Educting Nozzle of up to 1000 Gallons per Minute flow. In addition, the platform is designed to securely hold a 275 or 330 gallon Tote Tank which serves as a foam concentrate supply. A fully loaded Foam Tote Platform can be easily moved with any forklift truck rated to lift 5000 pounds at a distance of 24 inches from the fork base. This portable system provides plenty of flexibility and fire fighting power to your arsenal, and is available with a variety of options which allow you to custom build to suit your needs.

Features

- Direct nozzle concentrate pick-up connection to Tote Tank.
- Serrated bar grating walking surface prevents slipping while preventing buildup of mud or debris.
- Quick-release tank securing system.
- 3" in-line butterfly valve in monitor riser.
- Completely free standing without anchors at flows up to 1120 GPM at 125 PSI.
- Tie-down points provided at each corner allowing use on flat bed trailer or truck.

Applications

The Foam Tote Platform is an ideal alternative to the installation of fixed monitors and the handling of drums or pails, or the need for a foam tanker for interim or long term protection of a hazardous area. With the platform mounted and pre-piped monitor with a large foam concentrate supply, it can be placed into action as quickly as a water supply is connected. It does not require careful positioning since the monitor piping allows the water supply to be connected to either side of the platform.

Specifications

- Weight approximately 900 pounds, less tote tank and concentrate.
- Approximate full weight with concentrate:
 - 275 gallon tote: 3300 pounds
 - 330 gallon tote: 3850 pounds
- Dimensions:
 - Height to top of tank:.....53-inches
 - Width:.....59-inches
 - Length:.....85-inches
- Pre-piped with MMA 3 x 2-1/2 aluminum monitor.
- 2-1/2" Gladiator Nozzle, 500 gpm or 1000 gpm.
- 3" butterfly valve with 10-position lever operator to control water flow.
- Dual 4" or 5" Storz, 4" Male Hose Thread, or 2-1/2" Female Clappered Siamese water inlets, all with caps or plugs.
- Furnished with quick-connect adapter elbow and tote tank pressure/vacuum vent.
- Red Gloss Industrial Epoxy Finish.

Options

- Single 275 gallon or 330 gallon tote tank.
- National Foam concentrates.
- Red vinyl tote tank cover.
- Tote heaters, suitable for use in non-classified areas, or for use in areas classified Class I, Division 2.
- Any Gladiator Self-Educting Nozzle up to 1000 GPM.
- Gladiator – DA (Dual-Agent) Dry Chemical attachment with flows up to 30 pounds per second.
- Remote controlled monitors.
- Alternate self-educing nozzles to customer preference.

FOAM TOTE PLATFORM

NME060

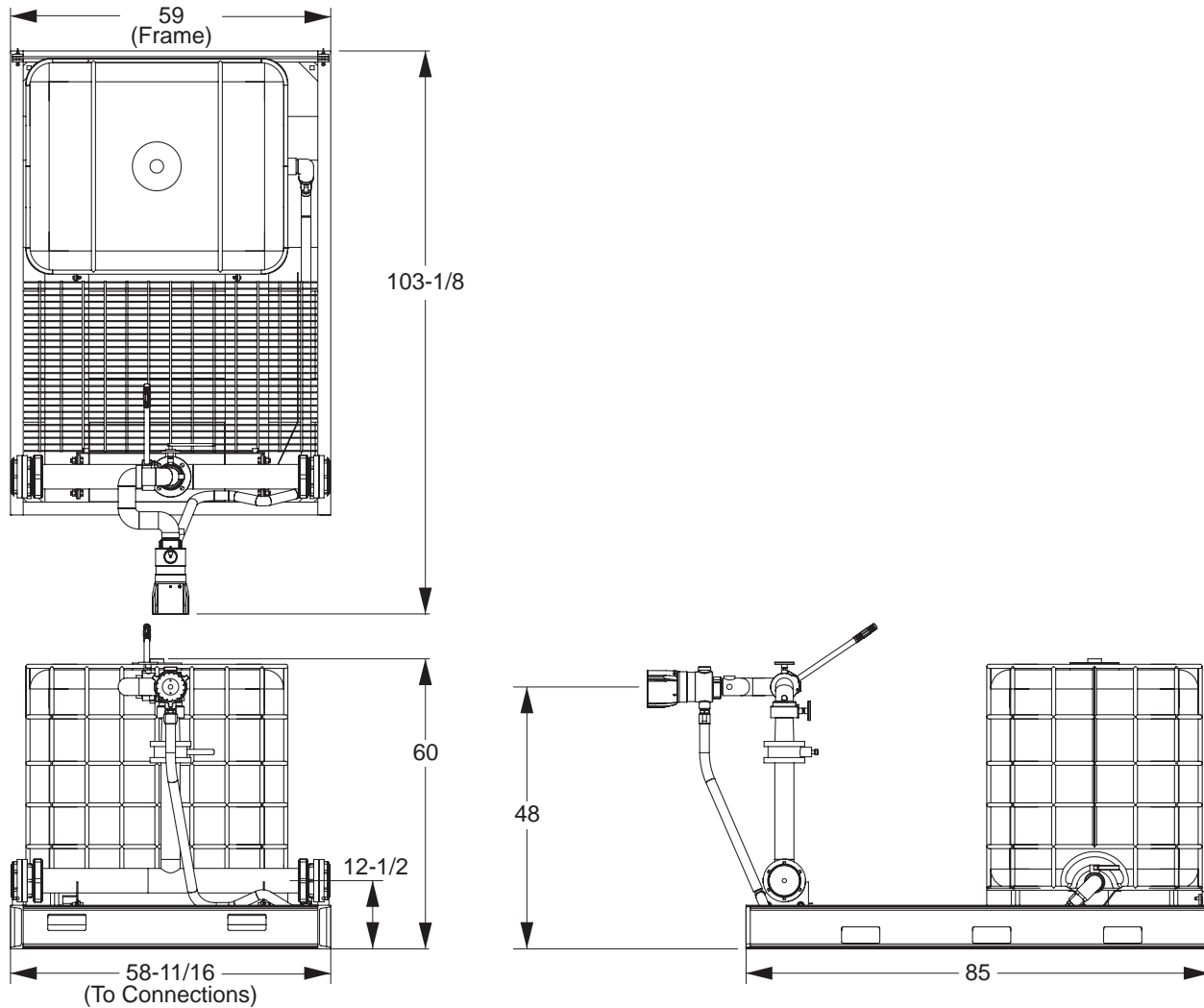

ORDERING INFORMATION

SINGLE TOTE PLATFORM - Structural Steel Base inlet adapters (as noted below with description), pre-piped MMA 3 x 2-1/2 monitor with any 2-1/2" Gladiator Nozzle (500 to 1000 GPM), 3" butterfly valve, quick connect tote connections, and pressure/vacuum vent.

5100-3000-1	Single Tote Platform - (2) Siamese 4" FNPT x 2.5" FSWNH
5100-3000-2	Single Tote Platform - (2) Adapter 4" FNPT x 4" MNH
5100-3000-3	Single Tote Platform - Adapter 4" FIPT Inlet x 4" Storz
5100-3000-4	Single Tote Platform - Adapter 4" FNPSH Inlet x 5" Storz

Note: Single Tote Platforms do not include foam tote or foam concentrate.