

MCS TYPE B FOAM MAKER & FOAM CHAMBER

NDD010

Approvals: UL, ULC

- Superior Foam Quality
- Operates At 30 PSI (2.1 bar) Minimum
- Tool Free Maintenance
- Corrosion Resistant Polyester Finish
- Double Aeration Foam Maker

Description

The MCS Type B Foam Maker and Foam Chamber is designed to introduce expanded foam directly onto the surface of a flammable or combustible liquid for fire extinguishment and/or vapor suppression. Classified as a Type II discharge device in accordance with NFPA Standard 11, foam chambers deliver low expansion foam directly onto the fuel surface with a minimum of foam submergence and fuel agitation. Minimizing submergence and agitation increases the effectiveness of the foam blanket, resulting in more efficient operation, and superior extinguishing capabilities. Foam chambers have the added advantage of directing all their flow directly onto the product surface regardless of weather conditions, for the most effective utilization of foam resources. Foam chambers have a long history of timely and safe control of numerous incidents.

Foam chambers are compatible with all types of foam concentrate; protein, fluoroprotein, AFFF, and AR-AFFF. They are generally installed on the side wall of vertical storage tanks above the maximum product level. Piping coupled to the unit can be linked to a fixed foam proportioning system, or terminated a safe distance from the tank, where foam solution can be delivered via mobile fire apparatus or portable foam proportioning equipment.

Features

- Four Sizes
- Superior Foam Quality
- Operates at 30 PSI (2.1 bar) minimum
- Tool Free Maintenance
- Corrosion Resistant Polyester Finish

Operation

MCS Type B Foam Chambers produce foam by introducing air into the foam solution stream. Foam solution can be delivered to the foam chamber in a variety of ways as previously noted. The inlet of the foam maker is fitted with a factory installed high efficiency venturi jet which is designed to draw air into the foam solution stream. The high efficiency jet produces superior quality foam, and results in operating pressures 25% lower than previously possible, now as low as 30 PSI (2.1 bar).

Air is drawn into the foam maker through a series of annular holes located around the integral foam maker. To prevent obstruction, the air inlet holes are protected by a stainless steel screen selected with a perforation size designed to exclude most known nesting birds and insects. The open area of the screen is designed to be no less than the total area of the foam maker air inlet holes.



The aerated foam solution then passes through a series of precisely designed mechanical agitation devices which maximize foam expansion, and enhance drainage time. The expanded foam then passes into the foam chamber body which is designed to further enhance expansion, and reduce the velocity of the foam stream prior to discharge onto the product surface.

The foam chamber is fitted with a frangible vapor seal located at the inlet to the discharge pipe connected to the storage tank. The vapor seal prevents the escape of product vapors into the atmosphere and/or foam system piping. The exclusive location of the vapor seal in the discharge piping, also prevents the escape of product into the foam chamber in the event of an overflow situation.

The flow of expanded foam ruptures the vapor seal at a predetermined pressure, allowing the foam to enter the tank. As the foam exits the foam chamber, it impacts the deflector which is designed to direct the flow against the wall of the tank to reduce the amount of foam submergence into the product, as well as dispersing it to each side for more complete coverage.

Approvals and Listings

- UL Listed
- ULC Listed

MCS TYPE B FOAM MAKER & FOAM CHAMBER

NDD010

Specifications

The entire assembly shall consist of the foam chamber body with integral foam maker, factory installed integral venturi style jet, deflector, deflector mounting hardware, and gaskets. A lifting lug designed to support the weight of the assembly shall be provided. The foam deflector shall be available in split or shallow configurations, and shall be suitable for bolting. The foam chamber body shall contain a frangible vapor seal positioned to prevent condensation and product vapors from entering the foam chamber body. The vapor seal shall be designed to rupture with a minimum inlet pressure of 30 PSI (2.1 bar) at the inlet to the foam chamber and shall withstand a maximum back pressure of 1.0 PSI (0.07 bar), or equal to 27 in. (686 mm) of water, as specified by API for welded storage tanks. The vapor seal is fabricated of graphite with a Teflon seal and is compatible with a wide range of corrosive chemicals. The vapor seal shall be a fully self-contained disc and shall not require adhesives, sealants, or loose gaskets to accomplish sealing. The vapor seal shall be held in place by a brass holder.

Access to the frangible vapor seal shall be accomplished through a removable top cover, without the need to remove retaining nuts. All nuts shall be designed to be captive to prevent loss.

All cover and vapor seal retaining hardware shall consist of stainless steel studs with brass nuts to resist galling, seizing, and corrosion. All carbon steel parts shall be abrasive blasted and coated with a fused polyester powder finish.

The foam maker and foam chamber shall be UL Listed for operation as low as 30 PSI (2.1 bar).

It shall be possible to test the foam maker and foam chamber assembly by removing the lid. Testing shall be accomplished with the vapor seal installed, and without damaging the seal. During testing the vapor seal shall prevent test solution from entering

the storage tank. No external sealing devices shall be necessary to accomplish testing. A drain shall be provided in the bottom of the foam chamber to allow for draining of the test solution. The drain shall be operable without tools.

Interchangeability

MCS Type B Foam Makers and Foam Chambers are dimensionally equivalent to prior Model MCS and MCS Type A Foam Makers and Foam Chambers. All customer connection points are identical, eliminating the need for piping modifications when replacing earlier versions. Orifice plates and vapor seals from previous models are not compatible with MCS Type B.

Selection

MCS Type B Foam Makers and Foam Chambers are available in four sizes to suit most requirements. Refer to the National Foam Engineering Manual, and the applicable design standards and local codes to determine the required flow rate for the application. The foam maker can be sized to provide any flow and pressure that falls within the operational limits of the foam maker. To select the correct size of foam maker, see the flow range charts on page 4, which show the operational limits of each foam maker. If the flow rate falls within the range of more than one unit, either size may be utilized. To determine the correct orifice, you must determine the design flow required and the available pressure at the foam maker inlet. Generally, the higher the operating pressure, the better the quality of the foam produced. The better the foam quality, the more efficient the operation, therefore, it is beneficial to utilize the highest operating pressure economically feasible. After the flow and pressure have been determined, they can be plugged into the formula shown on page 3 to determine the actual orifice size required. Once the orifice size is determined, confirm that it falls within the orifice range shown for the selected size of foam maker. The

required flow rate and inlet pressure must be specified when ordering.

Deflectors are available in split, shallow or split shallow configurations. The split deflector is designed to accommodate most installations, and can be installed from outside the tank. Shallow deflectors are intended for use when the tank is fitted with a floating roof which may pass over the deflector, minimizing possible damage to the roof seals. Shallow deflectors must be installed from inside the tank. The split shallow deflector is designed to accommodate most internal floating roof applications and can be installed from the outside of the tank. All Deflector mounting hardware is included. For the complete line of Deflector Kits and Future Assemblies please see NF data sheet NDD012.

Materials of Construction

Body:

- Carbon SteelASTM A569 & A53
- Stainless Steel316L ASTM A240

Jet/Receiver Silicon Bronze
ASTM B30 C87300

DeflectorCarbon Steel ASTM A569

Drain Plug.....Brass ASTM B62

Flange GasketsHigh Temp. Synthetic
Fiber w/ Nitrile or EPDM Binders

- Inlet Gasket 1/16"(1.6 mm)
- Discharge Gasket 1/8"(3.2 mm)

Vapor Seal Disk...Teflon Coated Graphite

Vapor Seal Holder..... Silicon Bronze
ASTM B62 C83600

Vapor Seal Gasket..... Teflon
Encapsulated Viton

Wing Nuts.....Brass ASTM B62

Internal and External..... Stainless Steel
Studs and NutsASTM 18-8

Air StrainerStainless Steel Perf 22 GA

Lid Gasket..... Silicon Foam - Close Cell
w/PSA Adhesive One Side

Finish:

- Foam Chamber Body and Deflector:
Abrasive blast to SSPC-SP6
Chemical wash, rinse and seal.
Heat Fusion Coated Polyester
Powder Coat, 3 mils DFT.
- All Other Components:
Natural Finish

MCS TYPE B FOAM MAKER & FOAM CHAMBER

NDD010

Orifice Jet Sizing - MCS Type B Foam Makers

All foam makers shall be sized using the following formula:

English	Metric
$D = \sqrt{\frac{Q}{29.8 \times C \times \sqrt{P}}}$	$D = \sqrt{\frac{Q}{0.6659 \times C \times \sqrt{P}}}$

Legend:
 Q - Flow in GPM (LPM)
 D - Diameter of Jet in Inches (MM)
 C - Coefficient of Discharge for the Jet (See Orifice Jet Sizing Chart)
 P - Pressure in PSI (BAR)

The following are the maximum and minimum jet sizes for each foam maker size and the C factor for each jet:

<u>MCS-9 (C = 0.920)</u>	<u>English</u>	<u>Metric</u>
Smallest Jet----- 0.504" (12.8016 mm) Dia	38.1 GPM@..... 30 PSI	144.4 LPM@..... 2.068 BAR
	49.1 GPM@..... 50 PSI	185.9 LPM@..... 3.447 BAR
	62.2 GPM@..... 80 PSI	235.5 LPM@..... 5.516 BAR
	69.6 GPM@..... 100 PSI	263.6 LPM@..... 6.895 BAR
Largest Jet----- 0.760" (19.3040 mm) Dia	86.7 GPM@..... 30 PSI	328.3 LPM@..... 2.068 BAR
	111.8 GPM@..... 50 PSI	423.2 LPM@..... 3.447 BAR
	141.6 GPM@..... 80 PSI	536.0 LPM@..... 5.516 BAR
	158.4 GPM@..... 100 PSI	599.4 LPM@..... 6.895 BAR
 <u>MCS-17 (C = 0.870)</u>		
Smallest Jet----- 0.721" (18.3134 mm) Dia	73.8 GPM@..... 30 PSI	279.4 LPM@..... 2.068 BAR
	95.2 GPM@..... 50 PSI	360.4 LPM@..... 3.447 BAR
	120.5 GPM@..... 80 PSI	456.1 LPM@..... 5.516 BAR
	134.8 GPM@..... 100 PSI	510.2 LPM@..... 6.895 BAR
Largest Jet----- 1.051" (26.6954 mm) Dia	156.9 GPM@..... 30 PSI	593.8 LPM@..... 2.068 BAR
	202.4 GPM@..... 50 PSI	766.1 LPM@..... 3.447 BAR
	256.2 GPM@..... 80 PSI	969.8 LPM@..... 5.516 BAR
	286.4 GPM@..... 100 PSI	1084.1 LPM@..... 6.895 BAR
 <u>MCS-33 (C = 0.973)</u>		
Smallest Jet----- 0.984" (24.9936 mm) Dia	152.5 GPM@..... 30 PSI	577.4 LPM@..... 2.068 BAR
	196.8 GPM@..... 50 PSI	745.0 LPM@..... 3.447 BAR
	249.0 GPM@..... 80 PSI	942.6 LPM@..... 5.516 BAR
	278.5 GPM@..... 100 PSI	1054.1 LPM@..... 6.895 BAR
Largest Jet----- 1.530" (38.8620 mm) Dia	371.8 GPM@..... 30 PSI	1407.3 LPM@..... 2.068 BAR
	479.6 GPM@..... 50 PSI	1815.5 LPM@..... 3.447 BAR
	607.0 GPM@..... 80 PSI	2297.7 LPM@..... 5.516 BAR
	678.8 GPM@..... 100 PSI	2569.4 LPM@..... 6.895 BAR
 <u>MCS-55 (C = 0.880)</u>		
Smallest Jet----- 1.457" (37.0078 mm) Dia	304.9 GPM@..... 30 PSI	1154.2 LPM@..... 2.068 BAR
	393.6 GPM@..... 50 PSI	1489.9 LPM@..... 3.447 BAR
	497.9 GPM@..... 80 PSI	1884.7 LPM@..... 5.516 BAR
	556.7 GPM@..... 100 PSI	2107.4 LPM@..... 6.895 BAR
Largest Jet----- 1.987" (50.4698 mm) Dia	567.1 GPM@..... 30 PSI	2146.7 LPM@..... 2.068 BAR
	731.6 GPM@..... 50 PSI	2769.4 LPM@..... 3.447 BAR
	926.0 GPM@..... 80 PSI	3505.2 LPM@..... 5.516 BAR
	1035.4 GPM@..... 100 PSI	3919.4 LPM@..... 6.895 BAR

MCS TYPE B FOAM MAKER & FOAM CHAMBER

NDD010

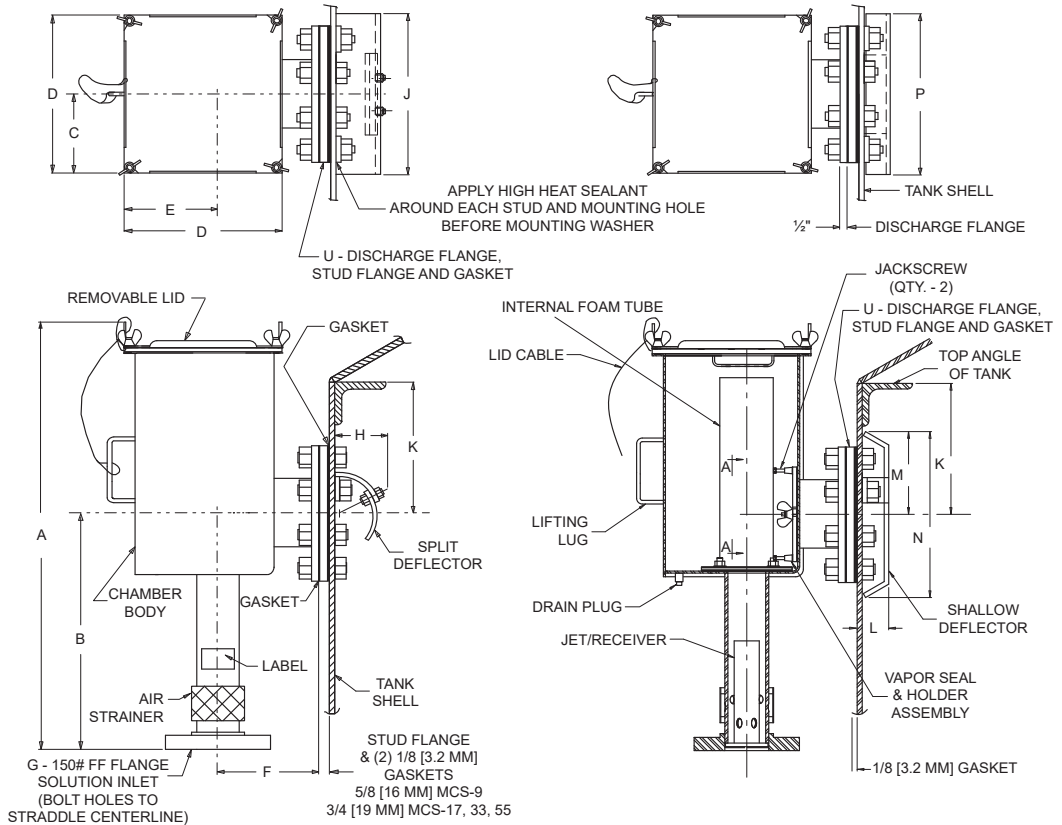

FOAM CHAMBER WITH SPLIT DEFLECTOR & STUD FLANGE

FOAM CHAMBER SECTION WITH SHALLOW DEFLECTOR

Note:
All dimensions are in inches (MM)

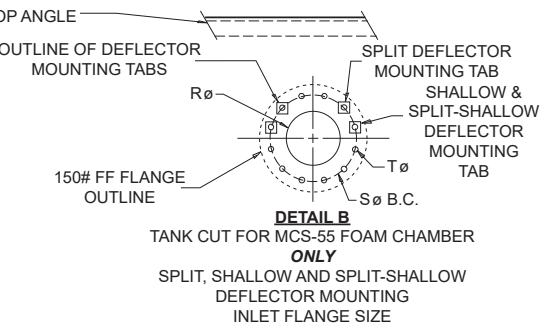
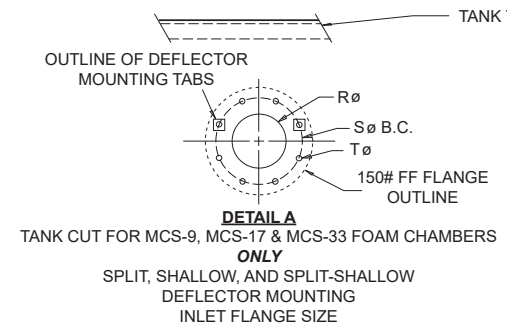

TYPE	A	B	C	D	E	F	G	H	J	K	L	M	N	P	R	S	T	U	WEIGHT
MCS-9 Type B	29-1/2 (479)	15-1/4 (387)	5-1/2 (140)	11 (279)	6-1/2 (165)	7 (178)	2-1/2 (64)	4 (102)	12 (305)	8 (203)	1-11/16 (43)	5-3/4 (146)	14-1/4 (362)	8-1/2 (216)	4-5/8 (117)	7-1/2 (191)	3/4 (19)	4 (102)	83 (37.6)
MCS-17 Type B	35-13/16 (910)	19-9/16 (497)	6-1/2 (165)	13 (330)	7-1/2 (191)	9 (229)	3 (76)	4-1/2 (114)	18 (457)	9-1/2 (241)	1-11/16 (43)	6-1/2 (165)	16 (406)	12 (305)	6-3/4 (171)	9-1/2 (241)	7/8 (22)	6 (152)	125 (56.7)
MCS-33 Type B	39-5/16 (999)	20-13/16 (529)	7-1/2 (191)	15 (381)	8-1/2 (216)	10 (254)	4 (102)	6 (152)	24 (610)	11 (279)	1-11/16 (43)	8 (203)	24-1/2 (622)	16 (406)	8-3/4 (222)	11-3/4 (298)	7/8 (22)	8 (203)	188 (85.3)
MCS-55 Type B	46-5/16 (1176)	25-7/16 (646)	8-1/2 (216)	17 (432)	8-1/2 (216)	12 (305)	6 (152)	6-3/4 (171)	30 (762)	12 (305)	3-1/2 (89)	9 (229)	23-1/4 (591)	20 (508)	10-7/8 (276)	14-1/4 (362)	1 (25)	10 (254)	285 (129.3)

MCS TYPE B FOAM MAKER & FOAM CHAMBER

NDD010

FOAM CHAMBER ORDERING INFORMATION			
SIZE	WITH SPLIT DEFLECTOR	WITH SHALLOW DEFLECTOR	WITH NO DEFLECTOR
MCS-9 (Red)	1253-1651-2	1253-1651-3	1253-1651-1
MCS-9SS	1253-1652-2	1253-1652-3	1253-1652-1
MCS-17 (Red)	1253-2651-2	1253-2651-3	1253-2651-1
MCS-17SS	1253-2652-2	1253-2652-3	1253-2652-1
MCS-33 (Red)	1253-3651-2	1253-3651-3	1253-3651-1
MCS-33SS	1253-3652-2	1253-3652-3	1253-3652-1
MCS-55 (Red)	1253-4651-2	1253-4651-3	1253-4651-1
MCS-55SS	1253-4652-2	1253-4652-3	1253-4652-1

NOTE: If a deflector other than noted here is required, a chamber "With No Deflector" and the required "Deflector Kit" must each be ordered separately. See National Foam Data Sheet NDD012 for the complete line of Deflector Kits and Future Assemblies. All mounting hardware is included in the kits and assemblies.

When ordering please supply the following information: tank identification, tank size and type, product being stored, flow and inlet pressure at each foam chamber, deflector type, foam concentrate type, and percentage of concentration.

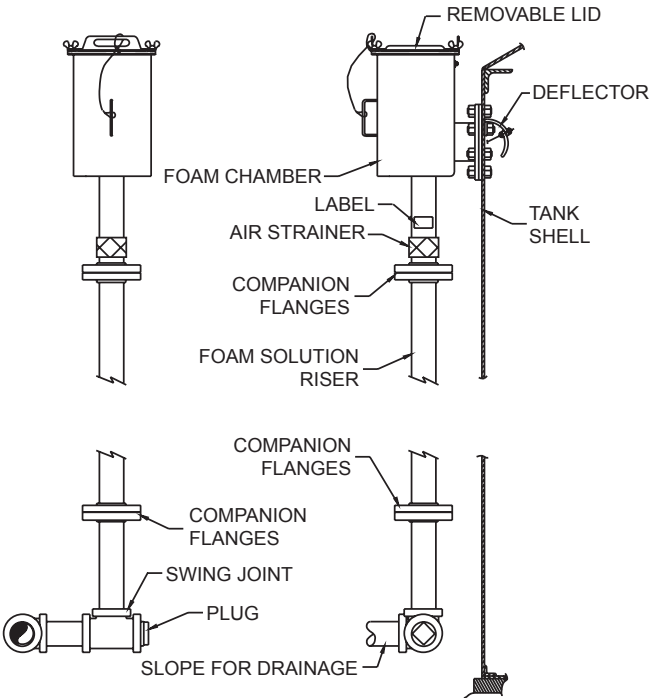

FOAM CHAMBER INSTALLATION



Split Deflector



Shallow Deflector



Split Shallow Deflector

MCS TYPE B FOAM MAKER & FOAM CHAMBER

NDD010

Vapor Seal Ordering Information

Vapor Seal Disks are available with or without the holder. Foam chambers shipped after October 2003 are provided with the brass vapor seal holder and require the purchase of only the vapor seal.

Foam chambers shipped prior to October 2003 have a vapor seal cartridge (graphite vapor seal, Viton seal & stainless steel holder) which is no longer available. Replacement vapor seals for these chambers require the purchase of the vapor seal kit

with holder. Future replacements only require the replacement of the vapor seal after installation of the brass holder. See pages 5 and 6 for Vapor Seal and Holder Mounting.

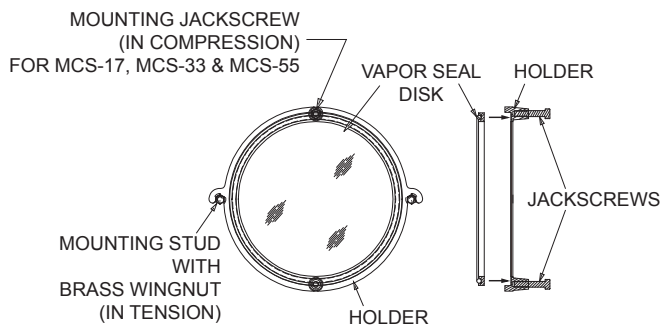

MCS-17, MCS-33 & MCS-55
VAPOR SEAL & HOLDER MOUNTING

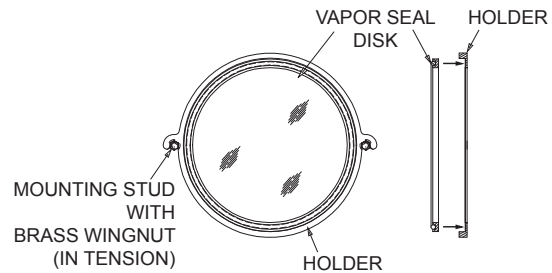

MCS-9
VAPOR SEAL & HOLDER MOUNTING

VAPOR SEAL ORDERING INFORMATION			
SIZE	COMPATIBLE JET ORIFICE SIZE	VAPOR SEAL DISK	VAPOR SEAL KIT WITH HOLDER
MCS-9 Low Flow	.504 - .620	1253-1840-7	1253-1840-5
MCS-9 Hi Flow	.621 - .760	1253-1840-8	1253-1840-6
MCS-17	ALL SIZES	1253-2840-7	1253-2840-6
MCS-33	ALL SIZES	1253-3840-7	1253-3840-6
MCS-55	ALL SIZES	1253-4840-7	1253-4840-6

Foam Chamber Accessory - Screen Guard

The Foam Chamber Screen Guard is designed to prevent birds and animals from entering the foam chamber through the chamber discharge flange opening. **NOTE: The Screen Guard is used on floating roof applications where the Vapor Seal is not used. The Screen Guard is ordered separately from the foam chamber.**

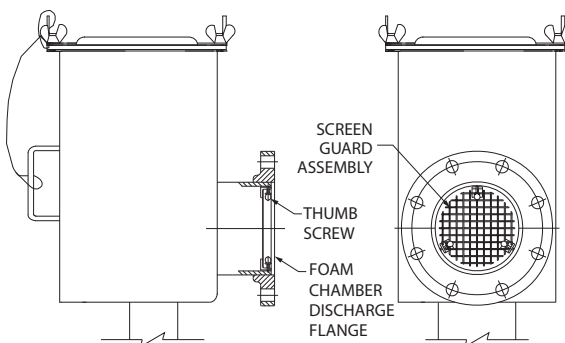

SCREEN GUARD ORDERING INFORMATION	
FOAM CHAMBER	SCREEN GUARD PART NUMBER
MCS-9	1253-1920-3
MCS-17	1253-2920-3
MCS-33	1253-3920-3
MCS-55	1253-4920-3