

GLADIATOR® DUAL-FLOW HIGH CAPACITY 1500 AND 3000 GPM FOAM/WATER NOZZLE

NDD185

- Self-Educting with Jet Pump
- Adjustable Air Aspirator
- Adjustable Stream From Full to Fog
- Two Flows In One Nozzle



Description

The Gladiator Dual-Flow Nozzle is a self educting, adjustable aspiration nozzle with two separate flow setting selections. The Gladiator Dual-Flow provides excellent nozzle range, ease of operation, and superior foam qualities that make it suitable for use with protein, fluoroprotein, AFFF, and AR-AFFF foam concentrates.

The Gladiator Dual-Flow nozzle gives the operator the ability to select either 1500 or 3000 GPM flow settings at 100 PSI by simply depressing and turning the baffle head tip at the discharge end of the nozzle. Switching from non-aspirating to full aspirating mode, while the nozzle is flowing, can be done by adjusting the air inlet control. Nozzle discharge pattern is controlled by adjusting the stream pattern sleeve on the nozzle body. The Gladiator Dual-Flow nozzle is particularly effective in firefighting applications when utilized with the National Foam Terminator II™ High Capacity Monitor.

The Gladiator Dual-Flow represents the latest advancement in foam fire fighting nozzle technology and delivers the most effective fire attack flexibility and performance, utilizing a totally new design. It is the first self educting nozzle designed for foam or water with the ability to deliver optimum performance with any foam concentrate.

Features

- Variable flow settings - 1500 & 3000 GPM

- Self-educting proportioning when used with remote jet pump (not included)
- Ring jet injection for complete foam mixing
- SelectAir™ adjustable aspiration for optimum foam quality
- Excellent stream range and quality
- Maximum nozzle performance with minimum stream fallout
- Compatible with all major types of foam concentrate
- Stream pattern fully adjustable
- Excellent water fog pattern suitable for vapor cloud mitigation
- Nozzle can be used without the pickup tube

Foam Proportioning

The Gladiator Dual-Flow is a self educting nozzle that can be used with a remotely located water driven jet pump proportioner. This offers the advantages of proportioning the foam concentrate supply a safe distance away from the fire. See Data Sheet NME020 for Jet Pump details.

The new Ring Jet Injection design incorporates eight equally spaced foam injection points surrounding the discharging water stream. This results in even distribution of the foam concentrate into the water stream to provide complete and homogenous foam mixing to maximize foam quality (expansion and 25% drain time) which is important for firefighting performance.

Since foam liquid discharges into the water stream in a parallel fashion, there is minimal disruption of the resulting foam stream during injection. The result is a high quality foam stream with minimal fallout and optimum range.

Foam Expansion

The Gladiator Dual-Flow's exclusive SelectAir adjustable aspiration feature gives the operator the ability to adjust foam expansion to maximize nozzle performance. The unique Air Tunnel delivers air into the center of the foam stream for even distribution and air entrainment. This enables more uniform foam expansion across the entire stream profile for optimum foam performance. The Air Tunnel has been independently verified to produce foam expansions of 6 to 1 or higher depending on the foam type and operating conditions. Firefighters now have the ability to balance nozzle range and foam expansion to suit the type of foam being used and the specific needs of the incident.

Large fully involved tank fires create significant thermal updraft which can carry away aspirated foam streams before they reach the fuel surface. Used in the non-aspirating mode, the Gladiator Dual-Flow can penetrate the thermal updraft and allow the foam to build on the fuel. Once a foam blanket has been established, the thermal updraft is broken and the nozzle can be easily switched to aspirating mode producing a longer lasting foam blanket. Switch

GLADIATOR® DUAL-FLOW HIGH CAPACITY 1500 AND 3000 GPM FOAM/WATER NOZZLE

NDD185

Foam Expansion (cont.)

over from non-aspirating to full aspirating can be done by simply adjusting the control handle while the nozzle is flowing. In aspirating mode, the nozzle produces a thick more homogenous foam blanket necessary to resist heat and the elevated vapor pressure of superheated fuels which can punch holes through an inferior foam blanket. The aspirating advantage becomes even more evident for vapor mitigation after the fire has been extinguished, during the long recovery period necessary to completely neutralize the incident.

Technical Data

Inlet Pressure:

- Minimum: 75 PSI (5.2 Bar)
- Nominal: 100 PSI (6.9 bar)
- Maximum: 125 PSI (8.6 bar)

Selectable Nozzle Flow Rates @100 PSI (6.9Bar):

- 1,500 GPM (5678 lpm)
- 3,000 GPM (11,355 lpm)

Inlet Connections:

- Water: 6" 150# FF ANSI Flange
- Foam: Dual 2"(51mm) FNPT

Materials of Construction:

- Body: Hardcoated Aluminum
- Hardware/Pattern Ring: Stainless Steel
- Pattern Sleeve: Spiral Wound Fiberglass

Weight: 65 lb. (29.5 kg)

Performance Data

Foam stream range figures are based on 25° to 30° nozzle elevation angle with still air conditions, mounted on a monitor 48" high.

GLADIATOR MODEL 1500					
Nozzle Pressure		Flow Rate		Straight Stream Range	
psi	bar	gpm	lpm	feet	meters
75	5.2	1299	4917	176	53.7
100	6.9	1500	5678	207	63.1
125	8.6	1677	6347	227	69.2

GLADIATOR MODEL 3000					
Nozzle Pressure		Flow Rate		Straight Stream Range	
psi	bar	gpm	lpm	feet	meters
75	5.2	2598	9834	249	75.8
100	6.9	3000	11355	300	92
125	8.6	3354	12695	330	101

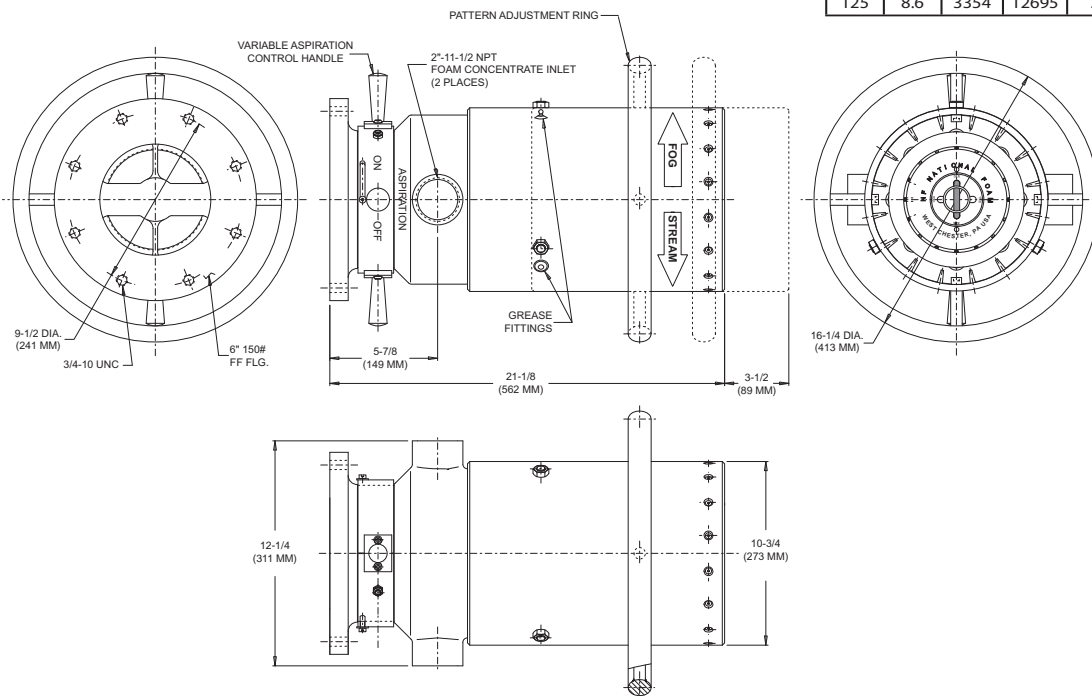

ORDERING INFORMATION

PART NUMBER	DESCRIPTION
1251-2531-5	Gladiator Dual-Flow

Note: Part number indicated reflects nozzle designed for use with jet pump kits. Consult factory for information on direct pickup models.