

# KF40 WIDE ANGLE ASPIRATED FOAM WATER NOZZLE

NDD405

- Under Equipment Foam Application Device
- Superior Foam Quality
- Stainless Steel Construction
- Seawater
- AR-AFFF/AFFF and Protein Compatible



## Description

The KF40 wide angle directional foam/water nozzle is constructed of stainless steel, and operates at a 3.1 K-factor. The nozzle is capable of being mounted in any position between full upright to full pendant. The nozzle is suitable for use with AR-AFFF/AFFF and Protein foam solutions.

## Features

- Capable of being mounted in any position between full upright to full pendant
- Lightweight, investment cast welded, high-grade stainless steel construction
- BSP or NPT inlet
- Special order inlets available upon request

## Applications

Ideal for containment areas, under hazard, under/over hazard, loading racks, heliports, and process areas.

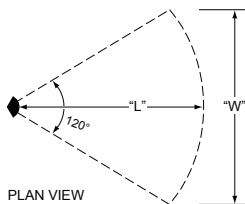

**Note:** Spray pattern based on nozzle mounted 36" (914.4 mm) above grade.

## Technical Data

### Description:

Foam/Water Nozzle

### Manufacturer:

National Foam

### Model:

Wide Angle

### K-factor:

3.1

### Connection:

3/4" FNPT (w/o adapter 3/4" BSP)

### Operating Range:

Minimum: 30 psi (2.07 bar)

Maximum: 100 psi (6.89 bar)

### Materials of Construction:

Body: 316 SS

Deflector: 316 SS

Finish: Plain

Flow / Pressure Chart	
Inlet Pressure psi (bar)	Foam Solution gpm (lpm)
100 (6.89)	31 (117)
80 (5.52)	28.7 (109)
70 (4.83)	26 (98)
50 (3.45)	22 (83)
30 (2.07)	16.5 (62)

Spray Pattern "In Air" Range Data		
Inlet Pressure psi (bar)	"L" - Length ft (m)	"W" - Width ft (m)
100 (6.89)	5.7 (1.74)	10 (3.05)
50 (3.45)	4.7 (1.43)	5.7 (1.74)
30 (2.07)	4 (1.22)	2 (0.61)

Note: Range is increased as foam 'pushes' across spill during operation.

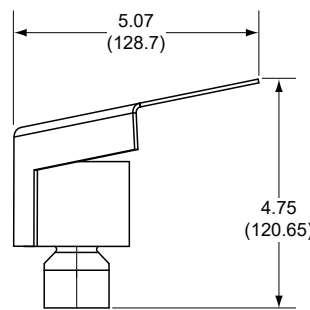

SIDE VIEW (UPRIGHT)

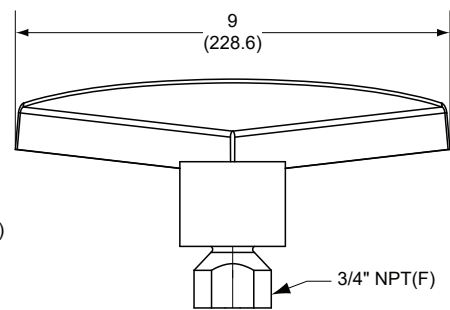

FRONT VIEW (UPRIGHT)

## ORDERING INFORMATION

Part Number	Description
1255-2834-2	KF40 Nozzle, Wide Angle 3/4 (F)NPT

06/19 NDD405 (Rev C)

Page 1 of 1

## National Foam

350 East Union Street, West Chester, PA 19382, USA  
24hr **RED ALERT**®: 610-363-1400 • Fax: 610-431-7084

[www.nationalfoam.com](http://www.nationalfoam.com)

National Foam operates a continuous program of product development. The right is therefore reserved to modify any specification without prior notice and National Foam should be contacted to ensure that the current issues of all technical data sheets are used.

© National Foam