

# JET PUMP PROPORTIONING FOR AROUND THE PUMP CONFIGURATION

NME025

- Marine System Compatible
- Portable/Fixed Installations
- Available as Loose Components
- Available as Portable Skid Assemblies
- Efficient Foam Education

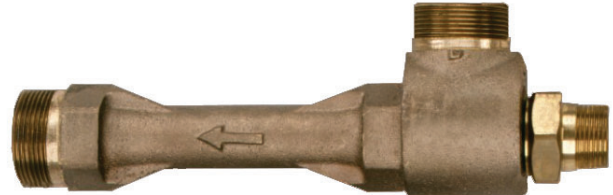

## Jet Pump Proportioning

Jet pumps are eductors that use water to perform the work of pumping foam concentrate from drums, tote tanks, or bulk tankers. The jet pump principle involves taking a high pressure water stream from the discharge of a pump unit and accelerating it through a tapered nozzle (jet) to increase its velocity, thus creating a negative pressure area. Foam concentrate is drawn into this negative pressure zone through an inlet connection located on the side of the jet pump body. Clear flexible pickup hose is used for inducting foam concentrate from storage containers to the jet pump. The foam concentrate is mixed with the jet pump water stream at an approximate ratio of 60/40 foam to water. This 60% (rich) foam solution is then recirculated through the suction of the same pump unit for boosting of the rich foam solution.

## Jet Pump Selection

There are several important factors involved in proper selection and application of National Foam jet pumps:

1. The jet pump foam induction rate must be matched to the overall system flow.

### Example:

- A. 2000 GPM Gladiator® nozzle requires a Model JP-2000-3% jet pump for 3% injection rate. The JP-2000-3% will induct about 65 GPM of foam concentrate or about 3% of 2000 GPM.

- B. Using two JP-2000-3% jet pumps in parallel will provide 3% foam induction rate for a total system flow of 4000 gpm.
  - C. Using five JP-2000-3% jet pumps in parallel will provide 3% foam induction rate for a total system flow of 10,000 gpm.
2. The size and length of hose lay between the jet pump discharge and suction inlet is critical for proper jet pump operation. Jet pumps are sensitive to back pressure imposed on the discharge outlet. When maximum discharge pressure limits are exceeded the jet pump will cease to induct foam concentrate at the proper rate. Table A on page 2 gives maximum hose lays for different hose sizes assuming jet pump inlet pressures from 100 to 150 psi. As can be seen from the table, allowable hose lay lengths increase with larger hose size and increased jet pump inlet pressure.
  3. Pick up tube sizing must be correct for proper jet pump operation. Refer to the Ordering Information for correct pick up tube kit selection.

## Pick-Up Tube Kits

There are several important factors involved in proper selection and application of National Foam jet pumps:

1. Each jet pump requires a pickup tube kit.
2. Dual jet pump kits (3% / 6% units) will require two of the desired pickup kits.

3. Dual pickup kit is required for 2000 gpm at 6% and 3000 gpm at 3%.
4. When tote tanks are used, the 2" hoses can be connected to the 2" male outlet on the tank. Tote tanks must be vented when foam is being removed. Bulk tanks can be connected and utilized in the same way.

## Maximum Allowable Friction Loss

See Table B.

## Deployment and Setup

Jet pump induction with a pumping unit consists of jet pumps in parallel, positioned in the system as shown in Figure 2.

The total combined sum of the selected jet pump flow rates must equal the desired system flow. Various flow rates are possible with the appropriate jet pump(s).

Proportioning is accomplished by supplying water from the pump unit discharge to the water inlet connections of the jet pumps and inducting foam into the water stream through the jet pump foam concentrate inlet, via pickup tubes connected to a foam concentrate supply. Foam solution discharge from the jet pumps is then directed back to the inlet connection on the pump unit inlet manifold.

## CAUTION

**Keep pump unit inlet pressure to a minimum during jet pump operation, preferably less than 10 psi. Refer to Table B for the appropriate jet pump inlet pressure.**

# JET PUMP PROPORTIONING FOR AROUND THE PUMP CONFIGURATION

NME025

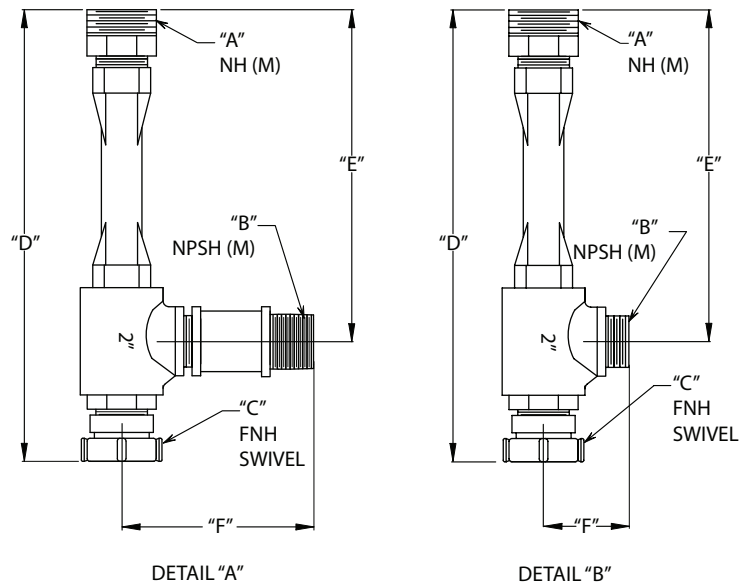

**FIGURE 1 - JET PUMP DIMENSIONS**

| MODEL NO.  | DESCRIPTION  | DETAIL | # OF JET PUMPS REQ'D | A              | B          | C              | D                | E                | F                  |
|------------|--------------|--------|----------------------|----------------|------------|----------------|------------------|------------------|--------------------|
| JP-1500-3% | 1500 GPM, 3% | A      | 2                    | 2-1/2"<br>(64) | 2"<br>(51) | 1-1/2"<br>(38) | 18-1/8"<br>(460) | 13-1/4"<br>(337) | 17-11/16"<br>(195) |
| JP-2000-3% | 2000 GPM, 3% | B      | 1                    | 2-1/2"<br>(64) | 2"<br>(51) | 1-1/2"<br>(38) | 18-1/8"<br>(460) | 13-1/4"<br>(337) | 3"<br>(76)         |

**TABLE A - MAXIMUM ALLOWABLE HOSE LENGTH CHART**  
Maximum Allowable Hose Lay in Feet (Meters) between the Jet Pump and the Pump Unit  
for Various Jet Pump Inlet Pressures-PSI (Bar)

| JET PUMP   | HOSE SIZE                            | 100psi (6.9) | 125psi (8.6) | 150psi (10.3) |
|------------|--------------------------------------|--------------|--------------|---------------|
| JP-1500-3% | 3" Hose 2-1/2" Couplings 2-1/2" Hose | 3100 (945)   | 3400 (1036)  | 3600 (1097)   |
|            |                                      | 1200 (366)   | 1300 (396)   | 1400 (427)    |
| JP-1500-6% | 3" Hose 2-1/2" Couplings 2-1/2" Hose | 1350 (411)   | 1650 (503)   | 1900 (579)    |
|            |                                      | 550 (168)    | 650 (198)    | 750 (229)     |
| JP-2000-3% | 3" Hose 2-1/2" Couplings 2-1/2" Hose | 2000 (610)   | 2150 (655)   | 2400 (732)    |
|            |                                      | 800 (244)    | 850 (259)    | 1000 (305)    |
| JP-2000-6% | 3" Hose 2-1/2" Couplings 2-1/2" Hose | 250 (76)     | 400 (122)    | 700 (213)     |
|            |                                      | 100 (31)     | 150 (46)     | 300 (91)      |

**TABLE B - MAXIMUM ALLOWABLE FRICTION LOSS CHART**

Maximum Allowable Friction Loss (psi [bar]) between the Jet Pump and Downstream Devices  
for Various Jet Pump Inlet Pressures (psi [bar])

| JET PUMP MODEL |                                | 100 psi (6.9) | 125 psi (8.6) | 150psi (10.3) |
|----------------|--------------------------------|---------------|---------------|---------------|
| JP-1500-3%     | Maximum Hose Loss (psi [bar])  | 21 (1.4)      | 26 (1.8)      | 30 (2)        |
|                | Foam Solution Flow (gpm [lpm]) | 93 (352)      | 98 (371)      | 102 (386)     |
| JP-2000-3%     | Maximum Hose Loss (psi [bar])  | 20 (1.4)      | 24 (1.7)      | 29 (2)        |
|                | Foam Solution Flow (gpm [lpm]) | 110 (416)     | 118 (447)     | 120 (454)     |

**Note:** Correct for elevation loss by subtracting .433 x elevation (ft) from maximum hose loss (psi) shown in Table B.

# JET PUMP PROPORTIONING FOR AROUND THE PUMP CONFIGURATION

NME025

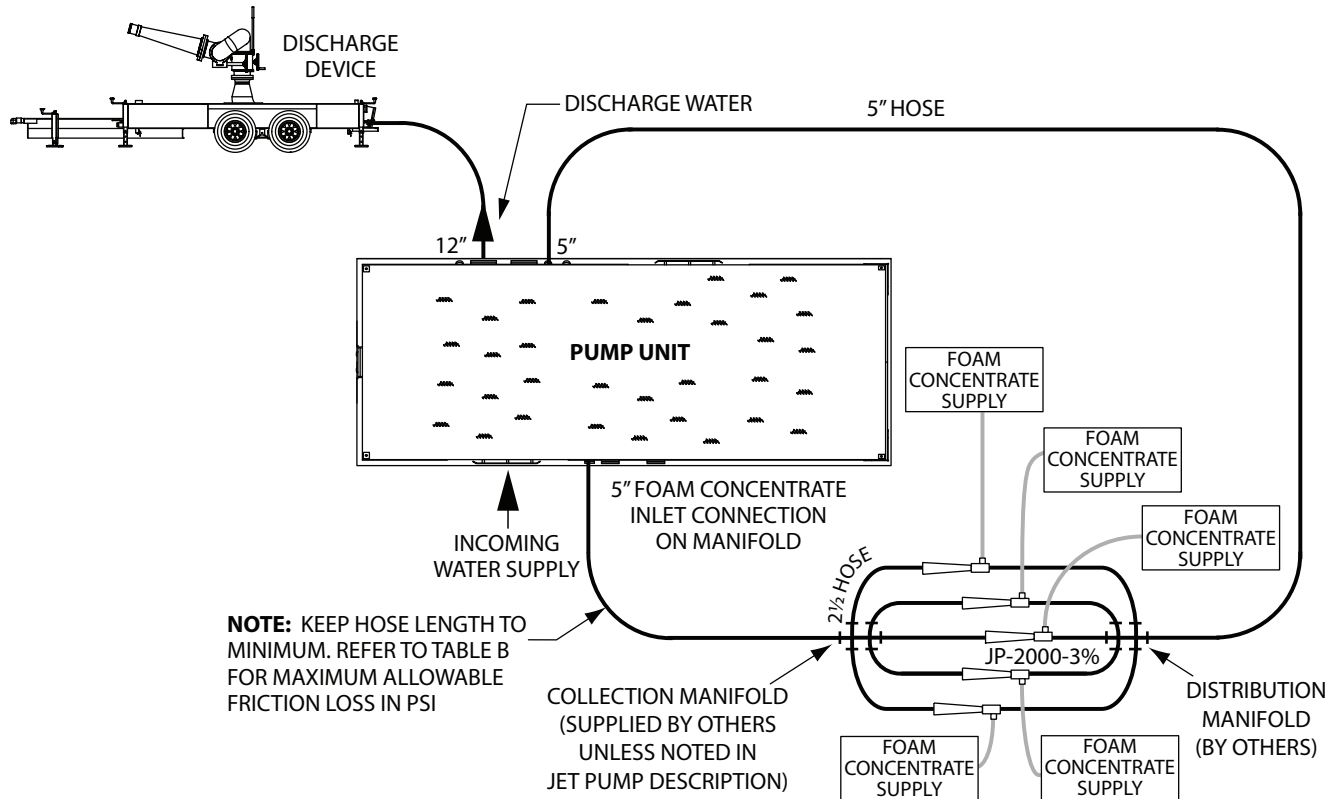

**NOTE:** KEEP HOSE LENGTH TO MINIMUM. REFER TO TABLE B FOR MAXIMUM ALLOWABLE FRICTION LOSS IN PSI

**FIGURE 2 - PICK-UP TUBE KIT/ARRANGEMENT**

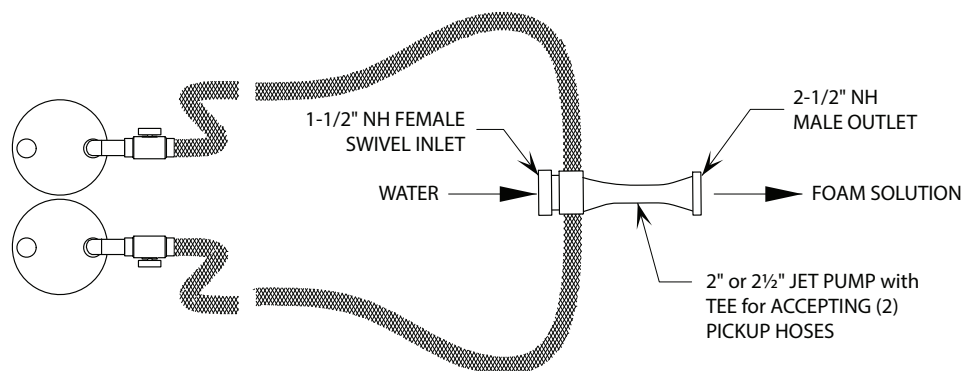

**Note:** When Tote tanks are used, the 2" hoses can be connected directly to the 2" male outlet on the tank.

**FIGURE 3 - PICK-UP TUBE KIT/ARRANGEMENT**

**Dual Pick-Up Tube Kit consisting of:** Two 2" brass pick-up tube dip tubes with shutoff valves and two clear pastic reinforced flexible pick-up hoses 12 feet long with 2" NPSH (straight pipe thread) couplings. Dual Pick-Up Kits also contain certain pipe fittings for interconnecting the pick-up hoses. This kit allows foam to be taken from two drums or two tote tanks simultaneously. The pick-up tube kit fits onto 2" NPSH male (straight pipe thread) connection at the jet pump foam inlet and dip tube, therefore, both jet pumps can be used with the pick-up tube kit.

**Dual Pick-Up Tube Kit NF Part Number:** 1252-0413-1

# JET PUMP PROPORTIONING FOR AROUND THE PUMP CONFIGURATION

NME025

| ORDERING INFORMATION |              |             |  |
|----------------------|--------------|-------------|--|
| Description          | Model Number | Part Number | Description  |
| 1500 GPM - 3%        | JP-1500 3%   | 1252-0412-0 | Single Jet Pump 1-1/2" FSWNH x 2-1/2" MNH Outlet   |
| 1500 GPM - 6%        | JP-1500 6%   | 1252-0412-1 | Dual Jet Pumps with 2-1/2" Siamese Fitting   |
| 2000 GPM - 3%        | JP-2000 3%   | 1252-0412-2 | Single Jet Pump 1-1/2" FSWNH x 2-1/2" MNH Outlet   |
| 2000 GPM - 6%        | JP-2000 6%   | 1252-0412-3 | Dual Jet Pumps with Collection Manifold<br>(Siamese - (2) 2-1/2" NH FSW in x 5" Storz out Clappered) |

## Pick Up Tube Kits

Pick up tube kits consist of 2" diameter dip tube(s) with shut off valve, clear plastic reinforced flexible pick up hose(s) 12 feet long with 2" NPSH (straight pipe thread) couplings. Dual and quad pick up kits also contain fittings for interconnecting the pick up hoses. All pick up tube kits fit onto 2" NPSH male (straight pipe thread) connection at the jet pump foam inlet and dip tube. Any jet pump can be used with single, dual or quad pick up tube kits listed below:

| Part Number | Description  |
|-------------|--|
| 1252-0413-0 | Single pick up tube kit consisting of 1 dip tube with shut off valve and 1 pick up hose. This kit allows foam to be taken from one drum or tote tank.  |
| 1252-0413-1 | Dual pick up tube kit consisting of 2 dip tubes with shut off valves, 2 pick up hoses, and interconnecting fittings. This kit allows foam to be taken from two drums or two tote tanks simultaneously.   |
| 1252-0413-2 | Quad pick up tube kit consisting of 4 dip tubes with shut off valves, 4 pick up hoses, and interconnecting fittings. This kit allows foam to be taken from four drums or four tote tanks simultaneously. |