

# FOAM TOTE COVERS

NME080

- Marine Grade Harsh Weather Rated
- Waterproof
- UV Resistant Non-Fading
- No Removal Necessary During Operation
- Over the Road or Stationary Applications
- Easy Washdown, Easy Store Fabric



## Description

The National Foam Tote cover is a simple, affordable but effective product used to protect foam totes from rain, snow, ice, ultraviolet rays and heat. Versions are available for both 275 and 330 gallon totes and are manufactured using red waterproof fabric. Tote covers are one piece construction to facilitate easy installation and removal and are suitable for over the road transport. Each tote cover is provided with a 2" wide polyester strap with zinc-plated cam buckle to secure the cover during transport or outside storage.

## Features

- Waterproof Fabric
- Foldable for Stowage
- No Tools Required
- Securing Strap
- Light Weight
- UV Resistant
- Affordable
- Fast Installation / Removal
- Standard Tote Sizes Available

## Use

The cover is installed by sliding over the top of the tote and fastening the securing strap to ensure an anchored fit onto the tote. Removal is simply the reverse of installation.

## Storage

To extend the life of the cover when not in use, clean, dry and fold the cover at room temperature into a neat fold and stow in a protected secure area such as a truck compartment or storage room.

## Purchasing Specification

The tote cover shall be assembled using UV resistant, all-weather fabric. The material shall be of a blended-through color and not a painted or coated color. The material shall be non-fading, non-stretch and non-fraying. The cover shall be designed to slide over and cover entirely, either a 275 gallon or 330 gallon ISO storage tote easily and be affixed quickly without tools. The cover shall be designed to be able to be used in stationary applications for Fire Fighting, in Mobile Applications where totes are transported over the road, and in storage applications. Openings shall be provided for user access to tote cap (On Top) and valve area (Lower Front) without removing the tote.

## Material Specification

National Foam tote tank covers are made of 18 oz. red vinyl waterproof fabric designed to protect from the harsh marine environment. This all-weather fabric is built to withstand the rigors of marine and outdoor environments and stand up to intense sun and harsh weather without fading, stretching, or fraying.

## Dimensions

275 Gallon Cover: 48" L x 40" W x 42" H  
330 Gallon Cover: 48" L x 40" W x 50" H

## Options

- 275 Gallon or 330 Gallon Sizes (Choose Correct P/N)
- Alternate Colors (Red Standard) (Call for Pricing)
- Sewn on Reflective Stripes (Call for Pricing)

**NOTE:** Photo shown for illustration purposes only. Final product may vary.

# FOAM TOTE COVERS

NME080

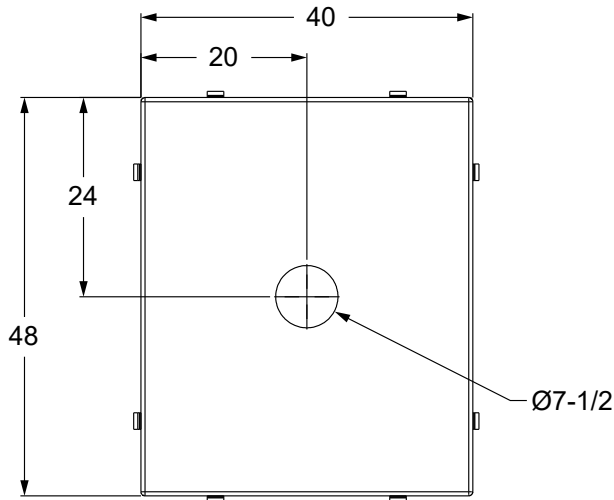

**TOP VIEW**

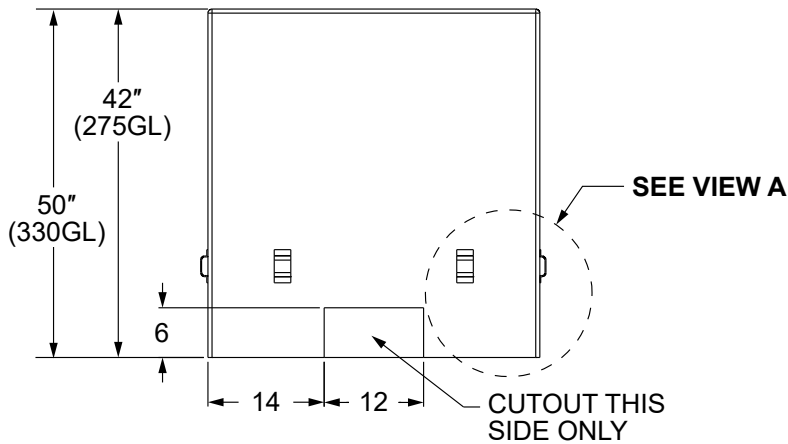
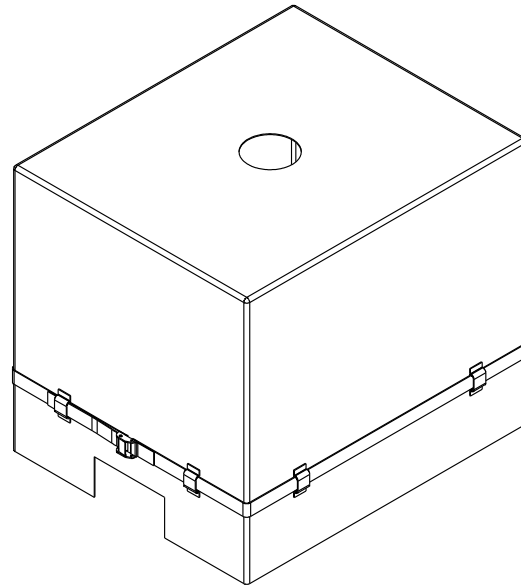

**FRONT VIEW**

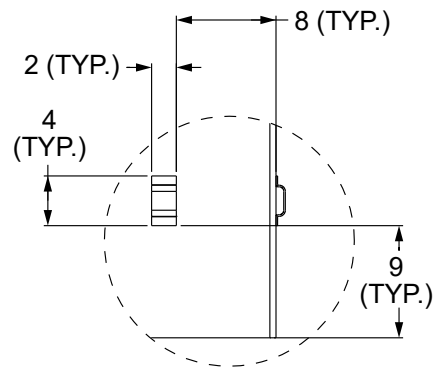

**VIEW A**  
BELT LOOP DETAIL  
(TYP. 8 PLACES)  
2 PER SIDE

**ORDERING INFORMATION**

Part Number	Description
1292-2000-1	275 Gallon Foam Tote Cover with Strap, Red
1292-2000-2	330 Gallon Foam Tote Cover with Strap, Red