

POLYETHYLENE STORAGE TANKS

NPR010

- Compatible With All National Foam Concentrates
- Light-Weight
- UV Stabilized
- Translucent-Permits Observation Of Foam Level Without Using Gauges



Description

Polyethylene Atmospheric Foam Concentrate Storage Tanks come in a variety of sizes, with storage capacities ranging from 55 gallons to 11,900 gallons. Standard tanks are constructed and installed in a vertical configuration. Polyethylene tanks are compatible with all NF foam concentrates.

Features

- High density cross-linked polyethylene for light-weight durability
- Superior chemical strength and impact resistance
- Wide range of sizes and capacities

Applications

Recommended storage for foam concentrates. Usable in climates ranging from -20°F (-29°C) to 120°F (49°C). Foam concentrate temperature storage limitations may affect range. Ideal for systems requiring foam concentrate pumps or systems utilizing line proportioners.

Technical Specifications

Tank shall be of the vertical configuration, and shall have a flat bottom and domed top. It shall be one-piece molded high density cross-linked polyethylene construction in accordance with current ASTM standards for impact resistance, density, tensile strength, elongation, high and low temperatures and flexural modulus. The polyethylene shall have UV stabilizers to prevent premature failure from exposure to UV radiation and shall have superior chemical resistance, strength and impact resistant properties. Nominal capacity of the tank shall be stored within the straight

wall section, thus allowing the dome area for thermal and filling expansion. All connections below the liquid level shall be thru-the-wall, bulkhead type gasket fittings. The tank shall be provided with a suction connection complete with internal siphon tube, return connection, pressure vacuum vent threaded connection, drain connection with valve and manway in expansion dome, and a liquid level switch threaded connection.

A brass pressure vacuum vent (sold separately) is to be installed to protect the tank from bulging or collapse during fluid movement operation.

Anti-vibration connections (sold separately), of the single sphere type, are to be installed for foam tank suction and return connections to prevent vibration from being transmitted to the tank connections. Anti-vibration connectors shall have flanged ends.

To comply with NFPA requirements, and to protect the foam pump at low foam concentrate levels, the tank shall be outfitted in the field with a micro-style, low level shutdown switch (sold separately).

To minimize foam concentrate contact with air and reduce the effects of evaporation and concentrate deterioration National Foam recommends Sealer Oil (sold separately) shall be added to cover the top surface of protein, fluoroprotein, AFFF, and AR-AFFF foam concentrates stored in the tank to a depth of approximately ¼-inch (Refer to National Foam Datasheet NFC950). Alternatively, for Fluorine Free Foam Concentrates (Synthetic), two (2) layers of 1-1/2 inch

polypropylene Foam Seal Spheres (hollow plastic spheres) may be floated on the surface of the concentrate to reduce evaporation (Refer to National Foam Datasheet NFC940).

Variables: Specify tank capacity and corresponding size (inches) of 150 lb. PVC flange connections and any special requirements or equipment options.

Materials of Construction

Tank and Manway:

Translucent, UV stabilized, high density, cross linked polyethylene, in accordance with ASTM Standard D- 1998-93

Fittings:

- 2"-6" 150# FF flanged suction and return - PVC (suction siphon tube - PVC)
- 1½" NPT Bulkhead for drain - PVC or stainless steel (varies by model)
- 2" NPT Bulkhead for pressure vacuum vent - PVC
- ¾" NPT Bulkhead for liquid level switch - PVC

Pressure/Vacuum Vent (NPR310):

Brass (sold and shipped separately)

Drain Ball Valve:

Brass

Flexible Connector (NPR320):

Neoprene (sold and shipped separately)

Low Level Shutdown Switch (NPR300):

(sold and shipped separately)

Options

- Custom dimensions/sizes
- Horizontal configurations
- Level switches (Additional)
- Hold down and seismic anchoring systems
- Insulation and heat tracing
- Custom connection sizes, quantity, type and location
- Fill Pump (NPR390)

POLYETHYLENE STORAGE TANKS

NPR010

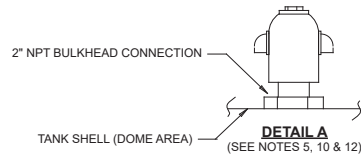
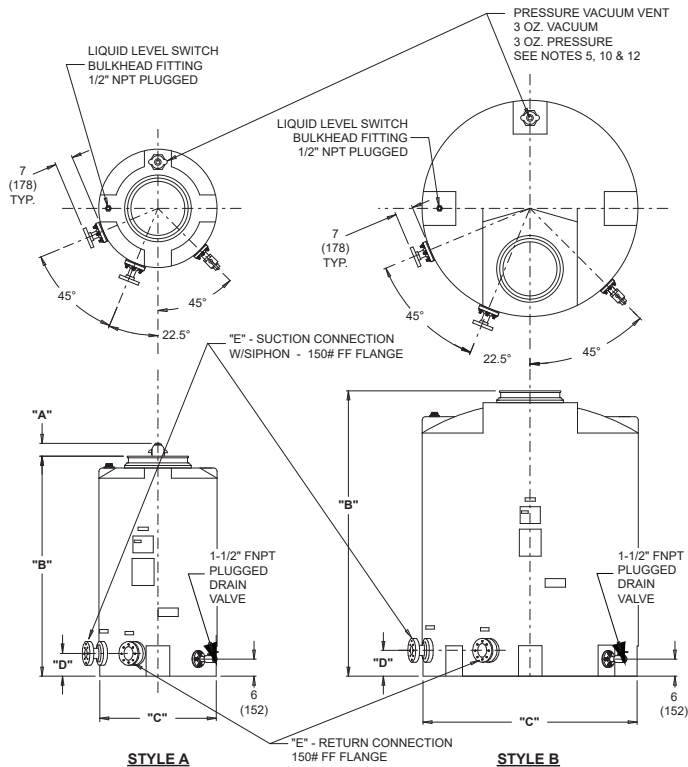

Notes:

1. All interconnecting piping must be adequately supported. Tank cannot support the weight of any piping. Flexible expansion joints must be used to allow for piping misalignment and tank wall flexing.
2. Piping and pipe supports between tank and proportioning equipment to be supplied by others.
3. A shutoff valve is recommended between the tank and the flexible connections to isolate the tank for servicing.
4. All tanks come with a threaded inspection hatch.
5. Inspection hatch and pressure vacuum vent locations may vary slightly.
6. All tanks have a flat bottom and must be located on a suitably supported flat level surface.
7. Dimensional references and accessories are typical for all tank sizes unless otherwise noted.
8. If level switch is used to shut down foam concentrate pump(s), one switch is required for each pump.
9. All National Foam concentrates stored in polyethylene tanks, except High Expansion 1-1/2%, Vapor Shield Acid, and Vaporshield-Alkali, shall be covered with 1/4" (6.4mm) layer of National Foam Sealer Oil.
10. Pressure vacuum vent shipped separately.
11. Tank capacities have been calculated based on straight wall volume only.
12. Shell shape varies slightly from illustrated as follows:
 - 65 gallon tank pressure vacuum vent located in the center of the manway.
 - 2400 gallon tank (Style D) does not have a flat area surrounding the manway therefore the liquid level switch bulkhead fitting is located in the dome area in the same approximate location. Fittings protrude 7" (178mm) from tank wall, rather than 6" as shown. Return connection is located 60° clockwise from drain and 30° from suction connection.
13. Drain valve bulkhead connection materials are stainless steel.
14. Drain and return connections are swapped for 4000 gal. tank.

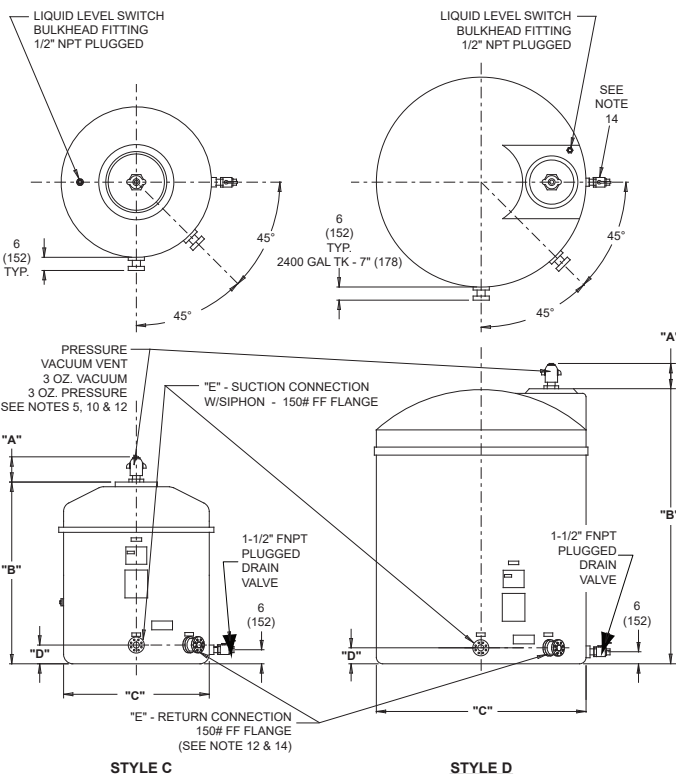

POLYETHYLENE STORAGE TANKS

NPR010

CAPACITY	A	B	C	D	E	Approx. Wall Thickness	Style Letter
55 (208 L)	10 (254)	41 (1041)	23 (584)	8 (203)	2 (51)	1/4 (6.35)	C
65* (246 L)	8 (203)	43-1/2 (1054)	23 (584)	8 (203)	2 (51)	3/16 (4.76)	A
100 (379 L)	10 (254)	65 (1651)	23 (584)	8 (203)	2 (51)	1/4 (6.35)	C
150 (568 L)	10 (254)	56-1/2 (1435)	31 (787)	8 (203)	2 (51)	1/4 (6.35)	C
200 (757 L)	10 (254)	73 (1854)	31 (787)	8 (203)	2 (51)	1/4 (6.35)	C
300 (1136 L)	10 (254)	53-1/2 (1359)	46 (1168)	8 (203)	2 (51)	1/4 (6.35)	C
550 (2082 L)	10 (254)	83-1/2 (2121)	48 (1219)	8 (203)	2 (51)	1/4 (6.35)	D
800 (3028 L)	10 (254)	116-1/2 (2959)	48 (1219)	8 (203)	2 (51)	5/16 (7.9)	D
900 (3407 L)	10 (254)	81-1/2 (2069)	64 (1626)	8 (203)	2 (51)	3/8 (9.5)	D
1150 (4353 L)	10 (254)	98 (2489)	64 (1626)	8 (203)	3 (76)	3/8 (9.5)	D
1400 (5300 L)	10 (254)	120 (3048)	64 (1626)	8 (203)	3 (76)	13/32 (10)	D
1900 (7192 L)	----	100 (2540)	86 (2184)	10 (254)	4 (102)	5/16 (7.9)	B
2250 (8517 L)	----	95 (2413)	96 (2438)	10 (254)	4 (102)	3/8 (9.5)	B
2400* (9085 L)	10 (254)	114 (2896)	86 (2184)	10 (254)	4 (102)	3/8 (9.5)	D
2600 (9842 L)	10 (254)	103 (2616)	96 (2438)	10 (254)	4 (102)	1/2 (12.7)	D
2750 (10410 L)	----	111 (2819)	96 (2438)	10 (254)	4 (102)	7/16 (11)	B
3800 (14385 L)	10 (254)	152 (3861)	94 (2388)	10 (254)	6 (152)	23/32 (18)	D
4000** (15142 L)	10 (254)	84 (2133)	143 (3632)	10 (254)	6 (152)	23/32 (18)	D
4900 (18549 L)	----	150 (3810)	105 (2667)	10 (254)	6 (152)	9/16 (14)	B
5200 (19684 L)	10 (254)	153 (3886)	110 (2794)	10 (254)	6 (152)	13/16 (21)	D
5350 (20252 L)	----	196 (4978)	96 (2438)	10 (254)	6 (152)	3/4 (19)	B
5900 (22334 L)	10 (254)	147 (3734)	120 (3048)	10 (254)	6 (152)	13/16 (21)	D
6250 (23659 L)	----	193 (4902)	105 (2667)	10 (254)	6 (152)	3/4 (19)	B
8100 (30662 L)	10 (254)	142-1/2 (3620)	143 (3632)	10 (254)	6 (152)	15/16 (24)	D
10100 (38233 L)	10 (254)	173 (4394)	143 (3632)	10 (254)	6 (152)	1-1/4 (32)	D
11900 (45046 L)	10 (254)	204 (5182)	143 (3632)	10 (254)	6 (152)	1-7/16 (37)	D

* See Note 12

** See Note 14

Note: All dimensions are in inches (millimeters)

POLYETHYLENE STORAGE TANKS

NPR010

ORDERING INFORMATION

Part Number	Capacity gal. (liters)	Empty Weight lb (kg)	Approximate Shipping Cube Ft ³ (M ³)	(Protein, FP, AFFF & AR-AFFF Foams) Amount Seal Oil Required gal. (liters)	(Fluorine Free Foams) Foam Seal Sphere Box Quantities (500 Spheres/Box) (2 Layers)
1217-2027-4	55 (208)	60 (27.22)	28 (0.79)	1 (4)	1
1217-2025-0	65 (246)	55 (24.95)	28 (0.79)	1 (4)	1
1217-2027-5	100 (379)	75 (34.02)	40 (1.13)	1 (4)	1
1217-2027-6	150 (568)	85 (38.56)	56 (1.59)	1 (4)	2
1217-2027-7	200 (757)	95 (43.09)	70 (1.98)	1 (4)	2
1217-2027-8	300 (1136)	115 (52.16)	104 (2.95)	2 (8)	4
1217-2028-0	550 (2082)	165 (74.84)	164 (4.64)	2 (8)	4
1217-2028-1	800 (3028)	215 (97.52)	222 (6.29)	2 (8)	4
1217-2028-2	900 (3407)	230 (104.33)	267 (7.56)	4 (15)	7
1217-2028-3	1150 (4353)	290 (131.54)	316 (8.95)	4 (15)	7
1217-2028-4	1400 (5300)	310 (140.62)	380 (10.76)	4 (15)	7
1217-2026-2	1900 (7192)	350 (158.76)	551 (15.60)	7 (26)	12
1217-2026-4	2250 (8517)	360 (163.30)	645 (18.26)	8 (30)	15
1217-2026-5	2400 (9085)	470 (213.19)	621 (17.59)	7 (26)	12
1217-2028-7	2600 (9842)	455 (206.39)	694 (19.65)	8 (30)	15
1217-2026-7	2750 (10410)	660 (299.38)	743 (21.04)	8 (30)	15
1217-2028-8	3800 (14385)	755 (342.47)	957 (27.10)	8 (30)	15
1217-2028-9	4000 (15142)	830 (376.49)	1008 (28.54)	18 (68)	34
1217-2027-1	4900 (18549)	830 (376.49)	1162 (32.90)	10 (38)	18
1217-2029-0	5200 (19684)	1205 (546.59)	1282 (36.30)	11 (42)	20
1217-2027-2	5350 (20252)	1400 (635.04)	1265 (35.82)	8 (30)	15
1217-2029-1	5900 (22334)	1502 (681.31)	1466 (41.51)	13 (49)	24
1217-2027-3	6250 (23659)	1600 (725.76)	1474 (41.74)	10 (38)	18
1217-2029-2	8100 (30662)	1810 (821.02)	1986 (56.24)	18 (68)	34
1217-2029-3	10100 (38233)	1921 (871.37)	2383 (67.48)	18 (68)	34
1217-2029-4	11900 (45046)	1991 (903.12)	2787 (78.92)	18 (68)	34

Note: 2" brass pressure vacuum vent required for all tanks listed. Request at time of order.
See NF Pressure Vacuum Vent Data Sheet NPR310.

ORDERING INFORMATION

Part Number	Foam Seal Item	Weight - Lb.(kg.)
1140-0101-6	1 Gallon Bottle Foam Seal Oil	7.2 (3.27)
1140-1340-6	5 Gallon Pail Foam Seal Oil	38 (17.24)
1140-1350-1	1 Box of 500 Foam Seal Spheres	5.0 (2.26)