

2" THREADED STYLE ILBP PROPORTIONING MODULES WITH CHECK VALVE

NPR180

Approvals: UL, ULC

- Zone Specific Foam Proportioning Device
- Seawater Compatible
- Proportioning Range 30- 180 GPM (114-681 LPM)
- 2%, 3%, 6% Proportioning

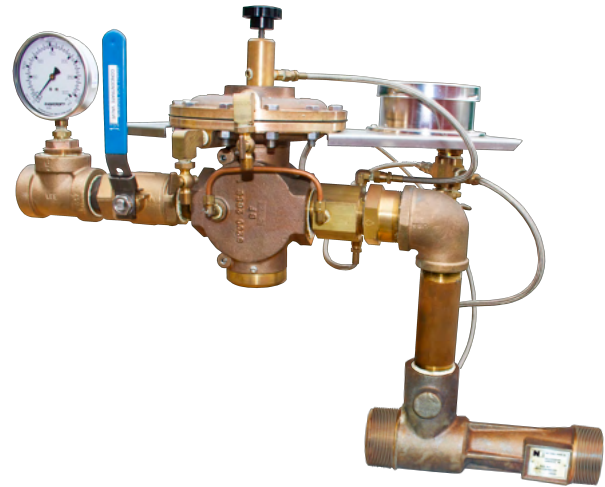

Description

The In-Line Balanced Pressure Proportioning Module is used in ILBP Proportioning Systems to provide accurate proportioning at multiple locations remote from the foam concentrate pump system and storage tank. A typical ILBP Proportioning Module consists of a threaded style ratio controller, check valve, manual ball valve and foam concentrate inlet pressure gauge. All components are factory assembled using corrosion resistant materials ready for installation into the customers water supply main. National Foam ILBP Proportioning Modules are capable of providing foam protection to all types of hazards on land and are also excellent for various marine applications.

The ILBP Proportioning Module automatically and accurately proportions foam concentrate over the proportioner flow range, regardless of pressure, without manual adjustments. Proper proportioning is achieved simply by maintaining identical water and foam concentrate pressures at the respective inlets of the ratio controller. The diaphragm balancing valve automatically adjusts the foam concentrate pressure to correspond to the water pressure when foam concentrate is supplied to the ILBP Proportioning Module, at a constant pressure, from the foam concentrate pump system.

As an option, the unit can be supplied with a manual override feature which includes a duplex gauge for monitoring

the balancing of the foam concentrate and water pressures at the ratio controller as well as allowing the system to be manually balanced in the event of the diaphragm valve failure.

Features

- May be used with either fresh or salt water.
- All foam concentrate valves, pipe and fittings are brass for compatibility with all types of foam concentrates, better corrosion resistance and reduction of sedimentation due to internal corrosion. All manual valves are brass or bronze ball valves, which provide low loss characteristics.
- Accurate proportioning over a wide flow range
- Fits easily into risers
- Allows for a centralized foam system
- Design working pressure of 250 psi (17 bar).
- Available in 3% or 6% injection for specific foam concentrate proportioning needs or can be supplied with a metering valve for variable proportioning.
- Allows independent selection of water or foam discharge on systems with multiple discharge devices.
- Module utilizes an integral check valve in the foam concentrate line to prevent backflow of water into foam proportioning system.

Applications

- Closed head foam-water sprinkler systems
- Aircraft hangars

- Flammable liquid warehouses, drum storage facilities
- Facilities requiring multiple foam injection points or risers
- Tank farms and dike protection
- Warehouses, offshore drilling rigs
- Docks, piers
- Any application requiring choice of water or foam application at multiple points

Specifications

The In-Line Balance Pressure (ILBP) Proportioning Module shall be a complete self-contained unit designed to proportion foam concentrate, with fresh or salt water, at the required percentage of concentration over the entire flow range of the ratio controller. See chart for appropriate flow range of proportioner. Foam concentrate shall be supplied to the module from a remote source, with a constant inlet pressure which exceeds the water pressure by 25 to 30 psi. The In-Line Balance Pressure (ILBP) Proportioning Module shall include all piping, valves and fittings necessary to comprise a complete foam proportioning unit and shall be factory assembled using corrosion resistant materials ready for installation into the customers water supply main. The assembled module shall be UL Listed and shall be rated for a working pressure of 250 psi (17 bar).

ILBP Proportioning Modules shall consist of a cast bronze, threaded style ratio controller (modified venturi proportioner). A pressure reducing control type diaphragm valve

2" THREADED STYLE ILBP PROPORTIONING MODULES WITH CHECK VALVE

NPR180

Specifications (cont.)

constructed of a brass body and diaphragm chamber with reinforced Buna-N diaphragm and stainless steel internals, shall be provided to automatically adjust the foam concentrate pressure to correspond to the water pressure. Balancing shall be accomplished by sensing the water and foam concentrate pressures at the inlet to the ratio controller and adjusting the diaphragm valve opening, to maintain the foam concentrate at the same pressure as the water. Teflon tubing, with stainless steel outer braid, shall be used for all pressure sensing lines. The foam concentrate piping shall include a full port brass ball valve for manual shutoff of the foam concentrate supply to the proportioner, a bushing type check valve and a pressure gauge to verify proper foam concentrate inlet pressure. The foam concentrate piping shall be schedule 40, brass pipe with threaded brass fittings and shall terminate in 1-1/2" FNPT inlet connections. As an option, the diaphragm valve can be provided with a hand wheel operated, manual override feature, which locks the diaphragm valve in the open position.

The manual foam concentrate shutoff valve is also used to allow manual regulation of the foam concentrate in the event of the diaphragm valve failure. A duplex gauge shall be provided to verify proper balance of the foam concentrate and water pressures at the ratio controller and also to allow the system to be manually balanced.

Approvals and Listings

- Underwriters Laboratories, Inc. (UL Listed)
- Underwriters Laboratories, Canada. (ULC Listed)

Technical Data

Ratio Controller:

Cast bronze, NPT connections

Piping:

Brass, Schedule 40, Screwed couplings

Manual Valves:

Ball valve, bronze body, & brass or chrome plated brass ball, 400# WOG

Diaphragm Valve:

Brass body with stainless steel internals, reinforced Buna-N diaphragm.

Check Valve:

Bushing type, brass body, 300 psig working pressure

Tubing:

Teflon with stainless steel overbraid

Hardware:

Stainless steel

Pressure Gauge:

Stainless steel case, 3-1/2" dial, 300 PSI (20.7 Bar) range [figure intervals 50 PSI (3.4 Bar), small graduations 5 PSI (0.3 Bar)], 1/4" LM connections, English & Metric, phosphor bronze bourdon tube, 1% accuracy

Working Pressure:

250 PSI (17 Bar)

Finish:

Natural

Duplex Gauge:

Stainless steel case, 4-1/2" dial, 400 PSI (27.6 Bar) range [figure intervals 50 PSI (3.4 Bar), small graduations 5 PSI (0.3 Bar)], 1/4" CBM connections, English & Metric, phosphor bronze bourdon tube, 1% accuracy (Manual override option only)

Options

- Manual Override
- Special Finishes
- Metering Valves
- Water Powered Foam Inlet Valve

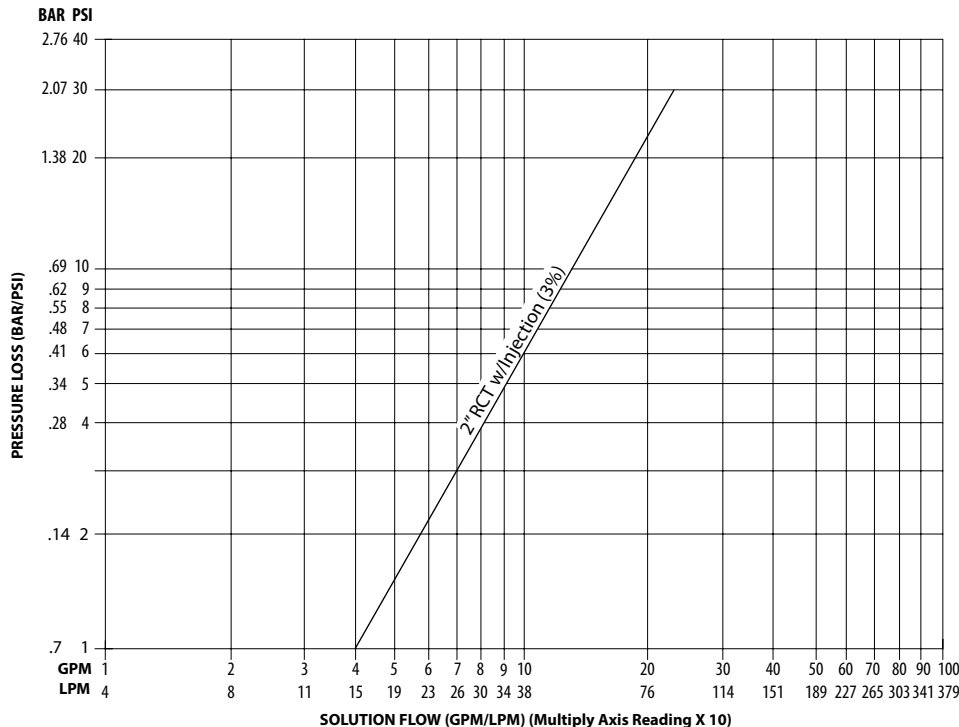

2" THREADED STYLE ILBP PROPORTIONING MODULES WITH CHECK VALVE

NPR180

NOM. PIPE SIZE	*PROPORTIONING RANGE - GPM (LPM)		TABLE OF DIMENSIONS INCHES (MILLIMETERS)						
	MIN	MAX	A	B	C	D	E	G	H
2	25 (95)	260 (984)	19-1/4 (489)	10-1/16 (256)	1-1/2 (38)	6-3/4 (172)	2-1/4 (57)	20-1/16 (506)	15-11/16 (399)

* Represents the overall flow range for all foam concentrates listed with respective ratio controller. Refer to UL directory for specific flow range for each foam concentrate.

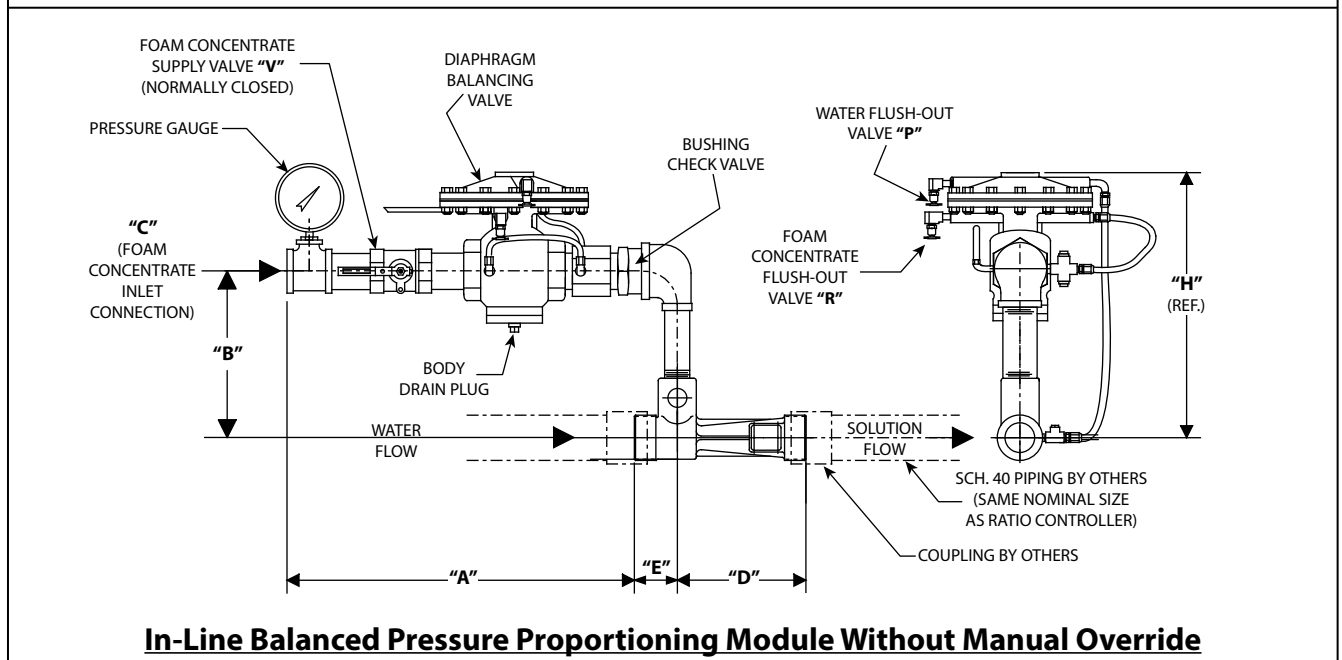
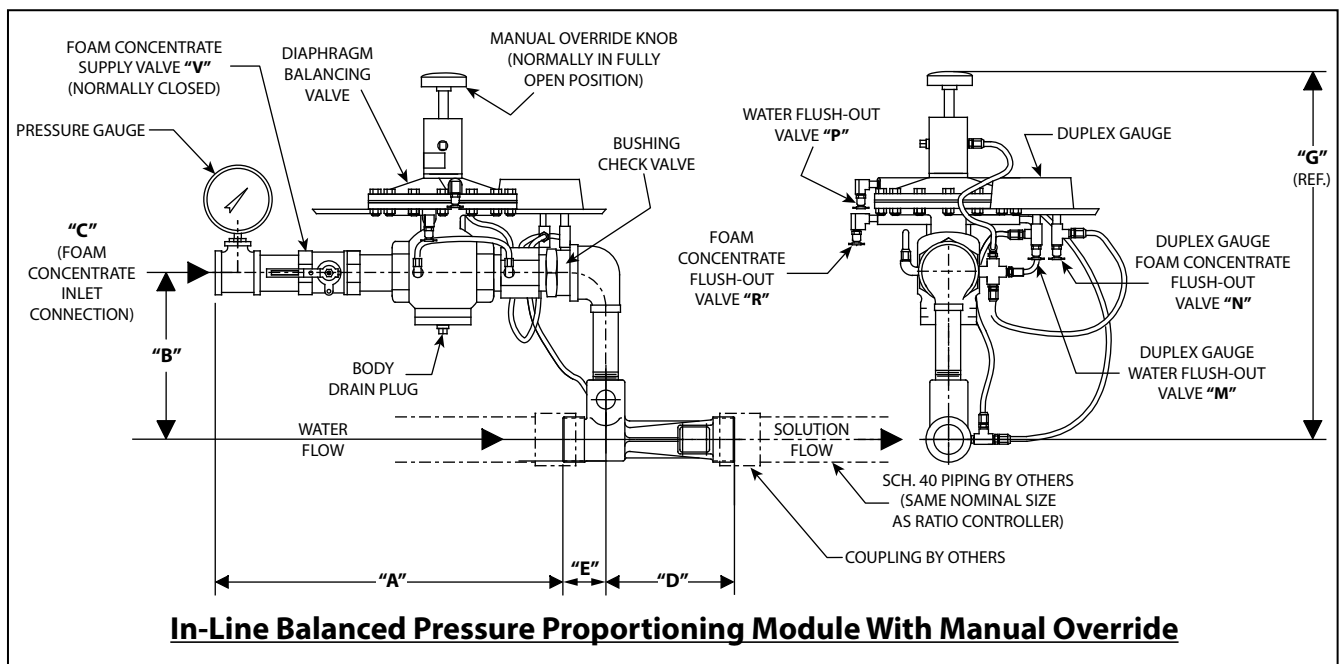

2" THREADED STYLE ILBP PROPORTIONING MODULES WITH CHECK VALVE

NPR180

ORDERING INFORMATION							
Size	%	Part #	Model #	Weight		Shipping	
				LBS	KGS	FT ³	M ³
2	2%	1233-9047-7	2BTC2-Hi-Ex	75	34.1	6.2	0.18
2	3%	1233-9047-0	2BTC3-P	75	34.1	6.2	0.18
2	3%	1233-9047-1	2BTC3-A	75	34.1	6.2	0.18
2	3%	1233-9047-2	2BTC3-U	75	34.1	6.2	0.18
2	3%	1233-9047-3	2BTC3-UG	75	34.1	6.2	0.18
2	6%	1233-9047-4	2BTC6-A	75	34.1	6.2	0.18
2	6%	1233-9047-5	2BTC6-U	75	34.1	6.2	0.18
2	6%	1233-9047-6	2BTC6-UCG6	75	34.1	6.2	0.18
2	3%	1233-9047-8	2BTC3-UGRN	75	34.1	6.2	0.18
2	2%	1233-9057-7	2BTC2-Hi-Ex-MOR	75	34.1	6.2	0.18
2	3%	1233-9057-0	2BTC3-P-MOR	75	34.1	6.2	0.18
2	3%	1233-9057-1	2BTC3-A-MOR	75	34.1	6.2	0.18
2	3%	1233-9057-2	2BTC3-U-MOR	75	34.1	6.2	0.18
2	3%	1233-9057-3	2BTC3-UG-MOR	75	34.1	6.2	0.18
2	6%	1233-9057-4	2BTC6-A-MOR	75	34.1	6.2	0.18
2	6%	1233-9057-5	2BTC6-U-MOR	75	34.1	6.2	0.18
2	6%	1233-9057-6	2BTC6-UCG6-MOR	75	34.1	6.2	0.18
2	3%	1233-9057-8	2BTC3-UGRN-MOR	75	34.1	6.2	0.18

MODEL NUMBER IDENTIFICATION

