

WDP-30

WHEELED DIAPHRAGM PROPORTIONERS 30 GALLON

NPR210

- Balanced Pressure Accuracy
- Compatible with All Foam Concentrates
- Portable Spill Fire Response
- 100 GPM
- 3% or 6% (other percentages available upon request)



Description

The WDP-30 is a complete self-contained one-man operated foam proportioning unit equipped with discharge hose and foam nozzle. The WDP-30 unit is equipped with wheels and handle for one-man mobility and is designed to satisfy the need for a dependable, high-quality mini-proportioner. Each WDP-30 unit is shipped completely assembled and includes as standard a National Foam JS-10 nozzle with ball shutoff, 50 feet (15.2 m) of 1 $\frac{3}{4}$ " hose, and a 30-gallon foam concentrate storage tank with fill funnel.

Features

- One-man operation
- Suitable for use with all foam concentrates
- Provided with 100 gpm (379 lpm) @ 100 psi (6.9 bar) nozzle
- Not subject to back pressure limitations of eductor type units
- Foam concentrate shutoff valve to permit alternate water-only operation
- Safety pressure relief valve to prevent tank pressurization beyond 200 psi (13.7 bar)
- Each unit provided with discharge hose and foam nozzle

Applications

Ideal for refining areas, docks, warehouses, aircraft hangars, offshore platforms, industrial process areas, and truck loading racks.

Technical Specifications

The National Foam WDP-30 shall be a complete self-contained proportioning system consisting of a bladder tank, ratio controller, discharge hose, and nozzle. The bladder tank shall be a welded carbon steel pressure vessel manufactured in accordance with ASME code, section VIII, and shall be supplied in the horizontal configuration with a capacity of 30 gal. (113.5 L) and a maximum working pressure of 200 psi (13.79 bar). It shall be fitted with a flexible, thermoplastic vulcanized rubber internal bladder to separate the foam concentrate from the incoming water. A 2" RCT ratio controller with integral 3% or 6% foam concentrate metering orifice shall be permanently piped to the tank. The proportioner shall have 1 $\frac{1}{2}$ " female hose thread inlet and 1 $\frac{1}{2}$ " male hose thread discharge connection, and shall have a proportioning range of 30 to 180 gpm (113.5 to 681 lpm). The foam concentrate piping shall include a ball valve with locking handle to allow for water-only operation. The water feed line to the tank shall include a safety relief valve to prevent over-pressurization of the tank. The unit shall have one valved foam concentrate fill connection (plugged) and a 1/2" NPT plugged vent connection. A foam concentrate fill funnel with male thread (1" NPT) shall be provided. The unit shall be equipped with semi-pneumatic rubber tires and handle. Tank and piping shall have red polyurethane finish.

The WDP-30 shall be complete with 50 ft (15.3 m) of 1 $\frac{3}{4}$ " double jacket

polyester rubber lined hose with light alloy hardcoated rocker lug 1 $\frac{1}{2}$ " NH or NPSH couplings and 100 gpm (379 lpm) aluminum air-aspirating nozzle with ball shutoff valve. Hose shall be stored in a hose bed mounted on top of the tank. Operating Instruction Plate shall be permanently mounted on tank.

Technical Information

Foam Concentrate:

Capacity	30 gal. (113.5 L)
Working Pressure.....	200 psi(13.79 bar)
Flow Range	30 to 180 GPM (113.5 to 681 lpm)
Min. Inlet Pressure	60 psi (4.1 bar)
Pressure Loss Through Proportioner	5 psi @100 gpm (0.34 bar @ 379 lpm)
JS-10 Nozzle Flow....	100 GPM @ 100 psi (379 lpm @ 6.9 bar)
Discharge Hose	50 ft (15 m) of 1 $\frac{3}{4}$ " hose w/ 1 $\frac{1}{2}$ " NH or NPSH cplgs.
Water Inlet.....	1 $\frac{1}{2}$ " NH or NPSH female swivel

Material of Construction:

Tank	Steel fabricated, ASME code
Diaphragm	Thermoplastic vulcanized rubber
Nozzle	Aluminum
Noz Shutoff Valve.....	Hardcoated aluminum
Proportioner	Cast brass
Wheels	Steel with semi-pneumatic rubber
Handle	Welded tubular steel
Proportioner.....	Cast Brass
Hose.....	Double jacket polyester rubber lined w/light alloy hardcoated rocker lug cplgs

WDP-30

WHEELED DIAPHRAGM PROPORTIONERS 30 GALLON

NPR210

Technical Information (cont.)

Finish:

Red polyurethane

Weight:

WDP-30350 lb (159 kg)

Full.....620 lb (281 kg)

OUTLINE DRAWING - WDP-30 WHEELED DIAPHRAGM PROPORTIONER

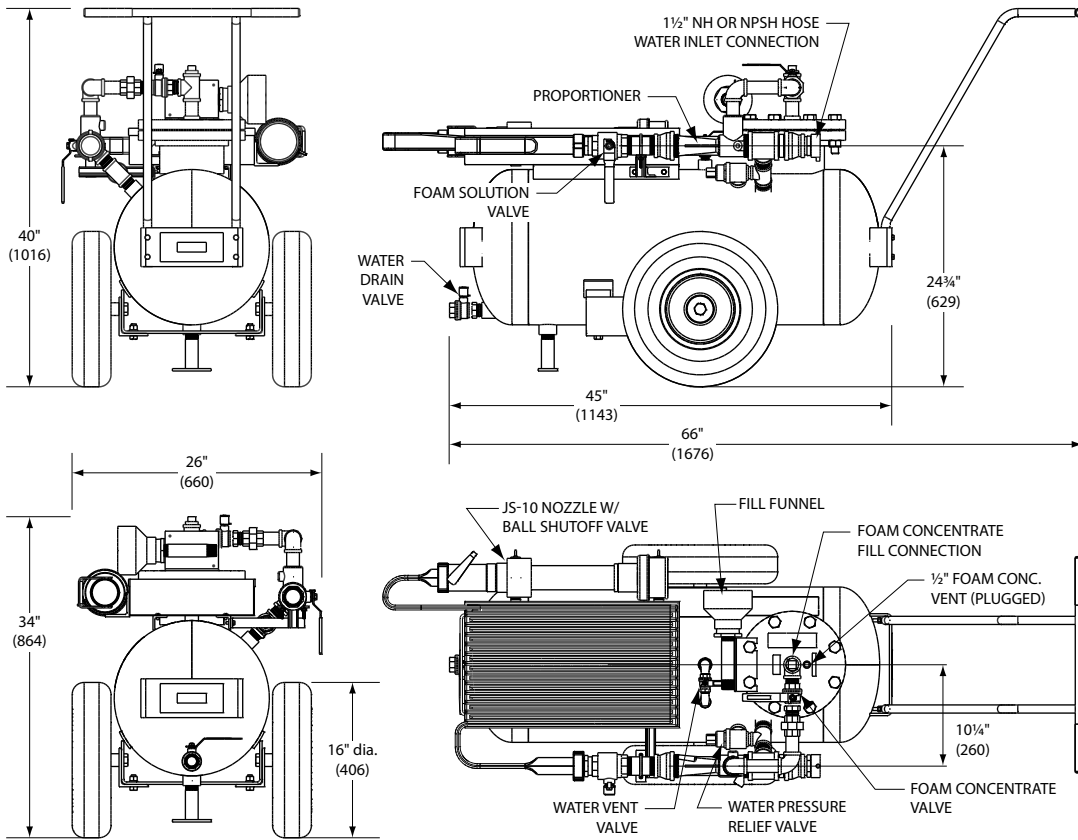

ORDERING INFORMATION

Model Number:	Part Number:	Description:
WDP-30-3%	1282-7025-1	Wheeled Diaphragm Proportioner, 30 gal, A/U-P, 1 1/2 NH Swivel Inlet w/ 50' 1 3/4 Collapsible Hose and JS-10 Nozzle
WDP-30-3%	1282-7027-1	Wheeled Diaphragm Proportioner, 30 gal, A/U-P, 1 1/2 NPSH Swivel Inlet w/ 50' 1 3/4 Collapsible Hose and JS-10 Nozzle
WDP-30-3%	1282-7025-4	Wheeled Diaphragm Proportioner, 30 gal, UGRN, 1 1/2 NH Swivel Inlet w/ 50' 1 3/4 Collapsible Hose and JS-10 Nozzle
WDP-30-3%	1282-7027-4	Wheeled Diaphragm Proportioner, 30 gal, UGRN, 1 1/2 NPSH Swivel Inlet w/ 50' 1 3/4 Collapsible Hose and JS-10 Nozzle
WDP-30-3%	1282-7025-3	Wheeled Diaphragm Proportioner, 30 gal, UG, 1 1/2 NH Swivel Inlet w/ 50' 1 3/4 Collapsible Hose and JS-10 Nozzle
WDP-30-3%	1282-7027-3	Wheeled Diaphragm Proportioner, 30 gal, UG, 1 1/2 NPSH Swivel Inlet w/ 50' 1 3/4 Collapsible Hose and JS-10 Nozzle
WDP-30-6%	1282-7030-1	Wheeled Diaphragm Proportioner, 30 gal, A/U-P, 1 1/2 NH Swivel Inlet w/ 50' 1 3/4 Collapsible Hose and JS-10 Nozzle
WDP-30-6%	1282-7032-1	Wheeled Diaphragm Proportioner, 30 gal, A/U-P, 1 1/2 NPSH Swivel Inlet w/ 50' 1 3/4 Collapsible Hose and JS-10 Nozzle
	1292-2600-2	Cover for WDP-30 Hose Station, Red Army Duck

National Foam

350 East Union Street, West Chester, PA 19382, USA
 24hr **RED ALERT**® : 610-363-1400 • Fax: 610-431-7084

www.nationalfoam.com

National Foam operates a continuous program of product development. The right is therefore reserved to modify any specification without prior notice and National Foam should be contacted to ensure that the current issues of all technical data sheets are used.

© National Foam