

PRESSURE SUSTAINING VALVE DUCTILE IRON BODY

NPR240

- Downstream Pressure Control Device
- Foam Concentrate Compatible
- 1-1/2" - 4" Sizes
- Epoxy Coated Interior/Exterior
- Brass/Stainless Steel Trim with Copper Tubing



Description

The Pressure Sustaining Valve is utilized within an In-Line Balanced Pressure (ILBP) Proportioning Pump system to automatically maintain a preset foam concentrate discharge pressure to the remotely installed ILBP Module(s). The valve modulates to maintain a minimum upstream pressure regardless of changes in demand down stream. Modulation of the main valve is controlled by a pilot valve, which senses upstream pressure. The pilot valve reacts immediately to changes in upstream pressure and in turn causes repositioning of the main valve spool to sustain the desired preset upstream pressure.

Features

- Suitable for use with all foam concentrates
- Operates automatically utilizing foam concentrate line pressure
- Heavy-duty, nylon reinforced diaphragm isolates upper chamber operating pressure from lower chamber line pressure
- Normally closed, direct acting spring loaded pilot for pressure adjustment
- Easily repaired and adjusted without removal from the foam concentrate line
- Pre-tapped bonnet and body for easy installation and removal of pilot control and /or pressure gauge
- Diaphragm assembly, guided top and bottom, is only moving part

- Center tapped bonnet facilitates installation of valve position indicator (optional)
- Ductile Iron body valves are epoxy coated inside and out with baked enamel exterior finish for maximum corrosion protection
- Pressure regulating valve has bleed line to allow flow through the valve thereby preventing air entrapment and concentrate drying in valve

Applications

- Pressure maintenance for ILBP proportioning system foam concentrate line

Specifications

The pressure sustaining valve shall be a globe pattern, diaphragm actuated valve, which throttles flow through the valve to maintain a minimum upstream pressure regardless of changes in demand downstream. A pilot valve, which reacts immediately to changes in upstream pressure, shall sense upstream pressure and modulate the main valve to sustain the desired preset upstream pressure.

The basic valve shall be a line pressure operated, diaphragm actuated, pilot controlled globe pattern valve. The valve body and bonnet shall be constructed of ductile iron and shall have threaded end connections (standard) or 150# FF Flanged connections (optional). The valve body shall have tapped ports on the upstream & downstream side to allow for installation of the pilot system. The valve

shall be designed for modulating service but shall have a resilient seat to provide positive shut off in the closed position. All internal parts shall be replaceable in the field without removing valve from the line. The stem of the basic valve shall be guided top & bottom. A stainless steel spring shall be located in the upper diaphragm chamber to assist in closing the valve against line pressure. All internal & external iron surfaces shall be epoxy coated with a two-part epoxy coating system.

The pilot control system shall include a pilot valve, shutoff valves, speed control valve, strainer and restricting orifices. A tamper resistant brass valve shall be installed at the up-stream port of the main valve to allow the pilot system to be serviced without shutting off the foam supply. The inlet to the pilot control shall be provided with a strainer to protect control piping and components from fouling due to particulate in the foam. The pilot shall be a direct acting, normally closed adjustable spring loaded diaphragm type valve. The pilot shall be field adjustable within the pressure control range of the spring. The up-stream side of the pilot control circuit shall be piped through a restricting orifice to the pilot valve and the upper side of the diaphragm chamber of the main valve. An adjustable valve shall be installed in the line feeding the upper side of the diaphragm chamber of the main valve to control the speed of the valve modulation. The upstream pressure port of the main valve shall

PRESSURE SUSTAINING VALVE DUCTILE IRON BODY

NPR240

Specifications (cont.)

be piped to the pressure sensing port of the pilot valve. A bleed line with restricting orifice shall be provided on the downstream side of the pilot valve to prevent entrapment of air and prevent foam concentrate from drying in valve, resulting in improper operation. The hydraulic circuit shall be completed by connecting the down stream port of the pressure relief pilot valve as well as the bleed line to the downstream side of the main valve. The control circuit shall be piped using copper tubing. The assembled valve with appropriate pilot shall be hydrostatically and operationally tested prior to shipment.

Technical Data

Materials of Construction:

Main Valve:

Body & Bonnet.....Ductile Iron
 StemStainless Steel ANSI 303
 SpringStainless Steel ANSI 302
 SpoolFederalloy ASTM I-836-F
 Diaphragm PlFederalloy
 ASTM I-836-FL
 Seat Ring....Federalloy ASTM I-836-FL
 Diaphragm.....Reinforced Viton
 O-Rings.....Federalloy ASTM I-836-FL
 BushingBronze, ASTM B-140-83

Pilot Valve:

BodyBronze, ASTM B62
 SpringStainless Steel ANSI 303
 InternalsStainless Steel ANSI 303

Control Circuit:

Tubing.....Copper (Type K)
 Fittings.....Brass
 Manual ValvesBrass
 Restricting Orifice.....Brass
 StrainerBrass

Pressure Rating:

Ductile Iron Threaded250 PSI
 (17.2 bars),
 Standard
 Ductile Iron 150# Flanged250 PSI
 (17.2 bars),
 Optional

Finish:

- Ductile Iron Body & Internals are Epoxy Coated
- Trim - Natural Copper & Brass

Options

- Flanged Valve

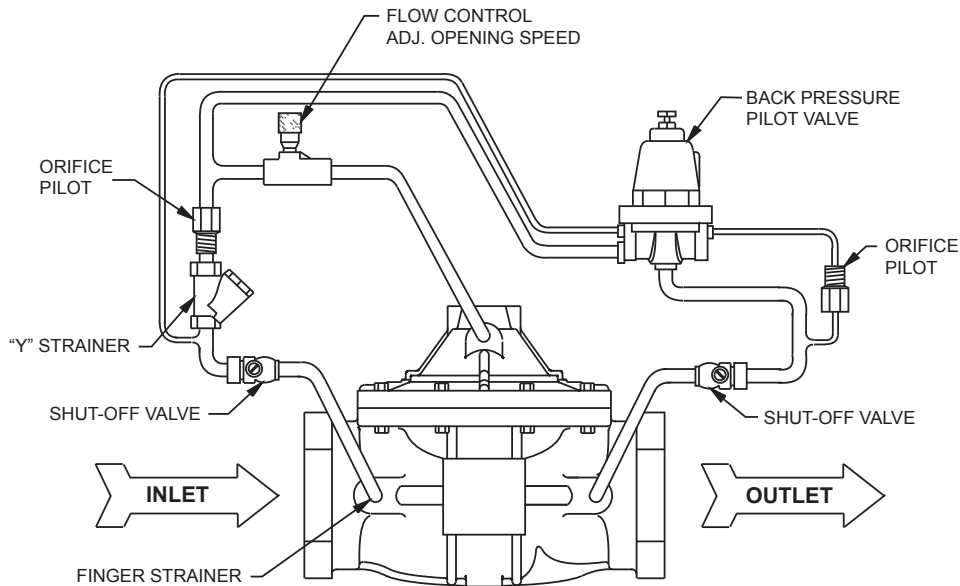

PRESSURE SUSTAINING VALVE

DUCTILE IRON BODY

NPR240

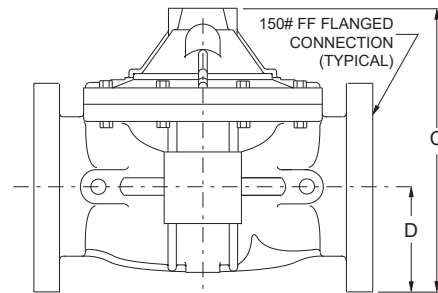
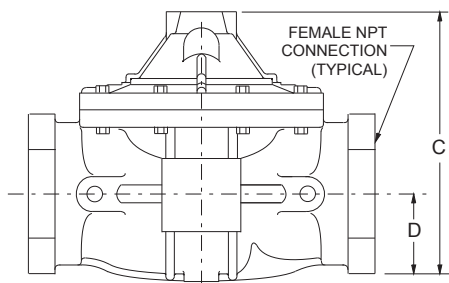
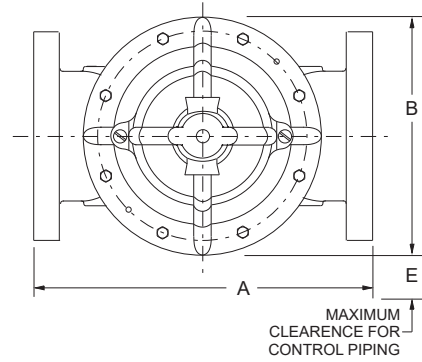
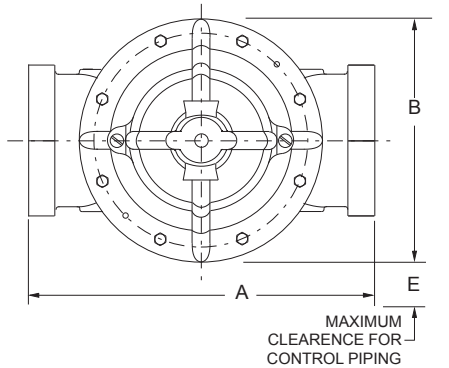

**Dimensional Drawing
Threaded Valve**

**Dimensional Drawing
Flanged Valve**

Dimensions											
Size	150# Threaded					150# Flanged					C _v
	A	B	C	D	E	A	B	C	D	E	
1-1/2"	9-15/16	6-11/16	6-13/16	1-23/32	10	9-3/16	6-11/16	7-1/2	2-3/16	10	28
	253	170	173	44	254	237	170	191	29	254	106
2"	9-15/16	6-11/16	6-13/16	1-23/32	10	9-3/16	6-11/16	7-1/2	2-3/16	10	50
	253	170	173	44	254	237	170	191	59	254	189
2-1/2"	9	6-11/16	9-1/2	3-1/2	10	10-7/8	6-11/16	10-1/32	3-9/16	10	105
	229	170	241	89	254	276	170	256	92	254	398
3"	10-1/2	6-11/16	11-5/8	3-3/4	10	10-7/8	6-11/16	10-1/32	3-9/16	10	110
	267	170	295	95	254	276	170	256	92	254	416
4"						14-1/8	8-1/4	12-3/16	4-1/4	10	200
						359	210	310	108	254	757

PRESSURE SUSTAINING VALVE DUCTILE IRON BODY

NPR240

NOTE:

Valve external body is supplied with blue epoxy coating. Trim is unpainted natural copper and brass.



ORDERING INFORMATION

Part Number	Description	Connection	Flow Range	Weight	
				Lbs	Kg
1231-1325-1	1-1/2" Pressure Sustaining Valve	NPT	15-125 GPM (57-473 LPM)	17	7.7
1231-1325-2	2" Pressure Sustaining Valve	NPT	15-208 GPM (57-788 LPM)	17	7.7
1231-1325-7	2-1/2" Pressure Sustaining Valve	NPT	20-300 GPM (76-1136 LPM)	39	17.7
1231-1325-8	3" Pressure Sustaining Valve	NPT	30-460 GPM (114-1741 LPM)	39	17.7
1231-1325-3	2" Pressure Sustaining Valve	150# FF Flg	15-208 GPM (57-788 LPM)	21	9.5
1231-1325-4	2-1/2" Pressure Sustaining Valve	150# FF Flg	20-300 GPM (76-1136 LPM)	44	20.0
1231-1325-5	3" Pressure Sustaining Valve	150# FF Flg	30-460 GPM (114-1741 LPM)	44	20.0
1231-1325-6	4" Pressure Sustaining Valve	150# FF Flg	50-800 GPM (189-3028 LPM)	104	47.2